

Technical Manual

**OPERATOR, UNIT, DIRECT SUPPORT AND GENERAL SUPPORT
MAINTENANCE MANUAL (INCLUDING REPAIR PARTS AND
SPECIAL TOOLS LISTS)**

**FAIRLEAD AND LAGGINGS
NSN 3815-01-153-1861**

Distribution: Approved for public release; distribution is unlimited.

DESTRUCTION NOTICE - Destroy by any method that will prevent disclosure of contents or reconstruction of
the document

HEADQUARTERS, DEPARTMENT OF THE ARMY

SEPTEMBER 1990

List of Warnings

Dry cleaning solvent P-D-680 is toxic and flammable. Wear protective goggles and gloves and use in a well ventilated area. Avoid contact with skin, eyes, and clothes and don't breathe vapors. Do not use near open flame or excessive heat. The flash point is 100 F - 138 F (38 C - 59 C). If you become dizzy while using cleaning solvent, get fresh air immediately and get medical aid. If contact with eyes is made, wash your eyes with water and get medical aid immediately.

Compressed air, used for cleaning purpose will not exceed 30 PSI. Use only with effective chip guarding and personnel protective equipment (goggles/ shield/ gloves, etc.).

CHANGE
NO.1

HEADQUARTERS
DEPARTMENT OF THE ARMY
WASHINGTON D.C., 11 September 1992

**OPERATOR, UNIT, DIRECT SUPPORT AND GENERAL SUPPORT
MAINTENANCE MANUAL (INCLUDING REPAIR PARTS AND
SPECIAL TOOLS LISTS)
FAIRLEAD AND LAGGINGS
NSN 3815-01-153-1861**

Current as of 21 April 1992

TM 5-3815-223-14&P, 12 September 1990, is changed as follows:

- 1 Remove old pages and insert new pages.
- 2 New or changed material is indicated by an asterisk adjacent to the new or changed material.

Remove Pages

2-1 and Figure 3
4-1
Bulk- 1
1-1 through 1-5

Insert Pages

2-1 and Figure 3
4-1
Bulk-1
I-1 through I-5

- 3 File this change sheet in front of the publication for reference purposes.

By Order of the Secretary of the Army:

Official:

MILTON H. HAMILTON
Administrative Assistant to the
Secretary of the Army
02899

Distribution:

To be distributed in accordance with DA Form 12-25-E, Block No. 5229, Operator, Unit, Direct Support and General Support maintenance requirements for TM 5-3815-223-14&P.

GORDON R. SULLIVAN
General, United States Army
Chief of Staff

Approved for public release; distribution is unlimited.

1/(2 Blank)

TECHNICAL MANUAL
NO. 5-3815-223-14&P

HEADQUARTERS
DEPARTMENT OF THE ARMY
Washington D.C., 12 September 1990

**OPERATOR, UNIT, DIRECT SUPPORT AND GENERAL
SUPPORT MAINTENANCE MANUAL
(INCLUDING REPAIR PARTS AND SPECIAL TOOLS LIST)**

**FAIRLEAD AND LAGGINGS
NSN 3815-01-153-1861**

Current as of 14 March 1990

REPORTING OF ERRORS

You can help improve this manual. If you find any mistakes or if you know of a way to improve the procedures, please let us know. Mail your letter DA Form 2028 (Recommended Changes to Publications and Blank Forms) or DA Form 2028-2 located in the back of this manual direct to: Commander, U.S. Army Tank-Automotive Command, ATTN: AMSTA-MB, Warren, MI 48397-5000. A reply will be furnished to you.

This technical manual is an authentication of the manufacturers commercial literature and does not conform with the format and contents specified in AR 310-3, Military Publications. This technical manual does, however, contain available information that is essential to the operation and maintenance of the equipment.

Distribution: Approved for public release; distribution is unlimited.

DESTRUCTION NOTICE - Destroy by any method that will prevent disclosure of contents or reconstruction of the document.

TABLE OF CONTENTS

	PAGE	ILLUS FIG
GENERAL INFORMATION	1	
DRAGLINE OPERATING CYCLE	1	
INSTALLING FAIRLEAD	1	
GENERAL	1	
INSTALLATION PROCEDURES	1	
REEVING.....	2	
REMOVING FAIRLEAD	2	
DRAGLINE BOOM POINT	2	
LAGGING	2	
GENERAL	2	
CHANGING LAGGINGS	2	
FAIRLEAD SERVICE	2	
GENERAL	2	
FAIRLEAD SHAFT BEARING REPLACEMENT	2	
ROLLER ASSEMBLY	2	
APPENDIX A. - REFERENCES	A-1	
APPENDIX B. - SUPPLEMENTAL OPERATING AND MAINTENANCE INSTRUCTIONS		
MAINTENANCE CONCEPT.....	B-1	
SHIPMENT AND STORAGE.....	B-1	
DESTRUCTION TO PREVENT ENEMY USE	B-1	
MAINTENANCE FORMS AND RECORDS.....	B-1	
LUBRICATION	B-2	
QUALITY DEFICIENCY REPORT (QDR).....	B-3	
EQUIPMENT IMPROVEMENT RECOMMENDATIONS (EIR)	B-3	
MAINTENANCE ALLOCATION CHART (MAC)	B-5	
OPERATOR/CREW PREVENTIVE MAINTENANCE CHECKS AND SERVICES	B-8	
UNIT PREVENTIVE MAINTENANCE CHECKS AND SERVICES	B-9	
MAINTENANCE AND OPERATING SUPPLY LIST.....	B-15	
EQUIPMENT PUBLICATIONS.....	B-17	
APPENDIX C. - REPAIR PARTS AND SPECIAL TOOLS LIST		
GROUP 06 ELECTRICAL SYSTEM		
GROUP 0608 MISCELLANEOUS ITEMS.....		
FAIRLEAD LIMIT SWITCH	1-1	1
GROUP 74 CRANE ATTACHMENTS		
GROUP 7411 CRANE DRAGLINE OR CLAMSHELL ATTACHMENTS	2-1	
FAIRLEAD DRAGLINE	2-1	2
SHEAVE BOOM POINT	3-1	3
GROUP 7416 SHAFTS	4-1	
DRAGLINE DRUM AND LAGGINGS	4-1	4
GROUP 95 GENERAL USE STANDARDIZED PARTS		
9501-BULK MATERIEL.....	BULK-1	
BULK MATERIEL	BULK-1	BULK

TABLE OF CONTENTS

	PAGE	ILLUS FIG
CROSS-REFERENCE INDEXES		
NATIONAL STOCK NUMBER INDEX	I-1	
PART NUMBER INDEX	I-2	
FIGURE AND ITEM NUMBER INDEX	I-4	
DRAGLINE OPERATING CYCLE	FO-1	

FAIRLEAD AND LAGGINGS

GENERAL INFORMATION

Figure 1 illustrates the fairlead and laggings for the Model 5060 crane. This manual is confined to lubrication, installation, removal, adjustment and general information concerning operation and maintenance of the fairlead and laggings. It also contains repair parts information.

DRAGLINE OPERATING CYCLE

The dragline operating cycle consists of five steps; casting the bucket, dragging (filling) the bucket, raising the loaded bucket, swinging, and dumping (see FO-1). The boom angle position is set before beginning operations.

The functions of the drums during dragline operation are tabulated below. The numbers in the column "controls" correspond to the items in Figure 2-1 of TM 5-3810-303-14, Page 2-3.

Drum	Function	Controls
Left	Dragline	5, 6, 23, 25
Right	Hoist Line	4, 8, 24, 26
Boom Hoist	Boom Hoist Line	11

INSTALLING FAIRLEAD

GENERAL. The fairlead installation includes installing the fairlead bracket, sheave assembly and limit switch assembly.

INSTALLATION PROCEDURE. To install the fairlead, proceed as follows (see Figure 2):

1. Set fairlead bracket (01) up to revolving frame bracket (02). Secure with pins (03) and hair pins (04).
2. Set sheave assembly (05) into fairlead bracket head. Secure with bearing retainer (06), lockwasher (07) and locknut (08).
3. Install limit switch as shown in Figure 3.



Use care when lowering the boom. Lower the boom slowly when the fairlead assembly in position. The limit switch will stop boom lowering if the boom contacts the fairlead head limit switch.

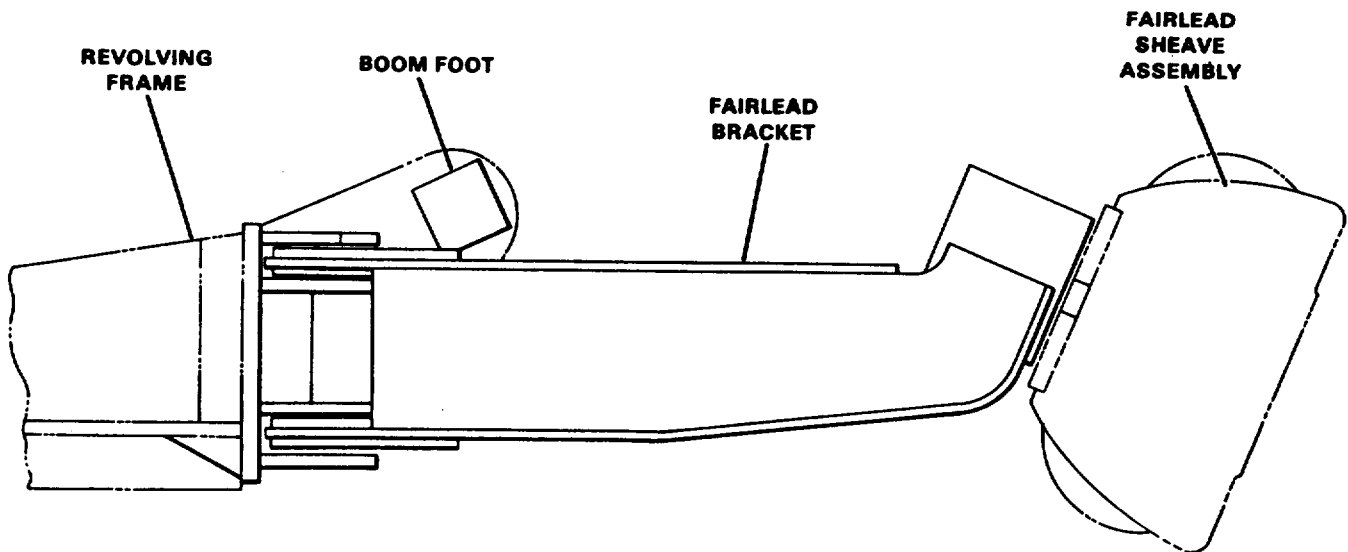

Figure 1. Fairlead and Laggings

4. The fairlead can be locked into position using pin (09) and hair pin (10). Rotate the fairlead so the sheaves are up and down, then insert pin (09) into fairlead head block (1) and into plate (12). Install hair pin (10).

NOTE

To fully lower the boom remove pin (03) closest to centerline of revolving frame and swing the fairlead out of the way.

REEVING. Reeving and rope size information for the drag- line (and a clamshell if used) are shown in Figure 4.

REMOVING FAIRLEAD

To remove the fairlead proceed as follows (see Figure 2):

1. Remove hair pin (10) and pin (09) to unlock fairlead.
2. Remove locknut (08), lockwasher (07) and bearing retainer (06). Remove sheave assembly (05).
3. See Figure 3 and disconnect cord grip at limit switch. Remove electrical lead from fairlead bracket. Coil up electrical lead and store for future use.
4. Support fairlead bracket (01) and remove hair pins (04) and pins (03). Remove bracket (01).

DRAGLINE BOOM POINT

The boom point used on the dragline is a single sheave with a dirt guard. See Figure 5 for the dragline boom point.

LAGGING

GENERAL. Different types of lagging are used depending upon the cable size and application (liftcrane, clamshell, dragline, etc.). Table 1 lists the laggings used on this machine.

Table 1. Laggings

Lagging No.	Drum	Cable Size	Type	Application
223J103	R. Side	3/4"	Spiral	R.H. Drag Hoist Lagging
223J105	L. Side	3/4"	Spiral	Lift Crane
223J106	R. Side	3/4"	Spiral	
223J107	L. Side	3/4"	Spiral	
223J108	L. Side	7/8"	Spiral	
223J122	R. Side	7/8"	Spiral	L.H. Drag Inhaul Lagging R.H. Hoist Shovel

CHANGING LAGGING. To change lagging does not require drumshaft removal. To change the lagging, proceed as follows (see Figure 6):

1. Remove all wire rope from the drum.
2. Remove the sheet metal from around both ends of the drum to gain access to the capscrews and lockwashers securing the lagging to the drum.

3. Rotate the drum to remove one-half of the lagging at a time.
4. Remove the cotter pins, lockwashers, and nuts securing the drum laggings together.
5. Remove the tie wire, capscrews and lockwashers securing the top half of lagging.
6. Rotate the drum and remove the tie wire, capscrews and lockwashers securing the other half of the lagging.
7. Set the new half piece of lagging on the drum. Secure with the lockwashers, capscrews and tie wire. Rotate the drum and repeat the procedure with the other half of lagging.
8. Install the rod bolt, lockwashers, nuts and cotter pins to secure the two drum laggings together.
9. Install the sheet metal removed to gain access to the lagging mounting hardware.
10. Reinstall the wire rope.

FAIRLEAD SERVICE

GENERAL. Fairlead service is limited to replacement of bearings in the sheave assembly and replacement of the rollers.

FAIRLEAD SHAFT BEARING REPLACEMENT. To replace the bearings in the fairlead shaft proceed as follows (see Figure 7):

1. Unlock fairlead by removing hair pin (01) and pin (02).
2. Remove locknut (03), lockwasher (04) and bearing retainer (05). Remove sheave assembly (06).
3. Remove bearing (07), spacer (08) and bearing (09) from fairlead shaft. Remove bearing retainer (10). Inspect bearings and replace if necessary.
4. Install bearing retainer (10), bearing (09), spacer (08) and bearing (07).
5. Set sheave assembly (06) into fairlead head and secure with bearing retainer (05), lockwasher (04) and nut (03).
6. Lubricate bearing cavity with GAA grease.
7. Rotate sheave assembly (06) into position. Install pin (02) and hair pin (01).

FAIRLEAD SHEAVE REPLACEMENT. To replace the sheave, proceed as follows (see Figure 8):

1. Remove capscrew (01) and lockwasher (02).
2. Remove rod end (03) and remove pin (04). Remove sheave (05) from sheave assembly (06).
3. Inspect the bearings in the sheave and replace if necessary.
4. Install sheave (05) into sheave assembly(06) and secure with pin (04).
5. Install rod end (03) into pin (04) and secure with lockwasher (02) and capscrew (01).
6. Lubricate sheave bearings with GAA grease.

ROLLER ASSEMBLY. To repair the roller assembly, proceed as follows (see Figure 9):

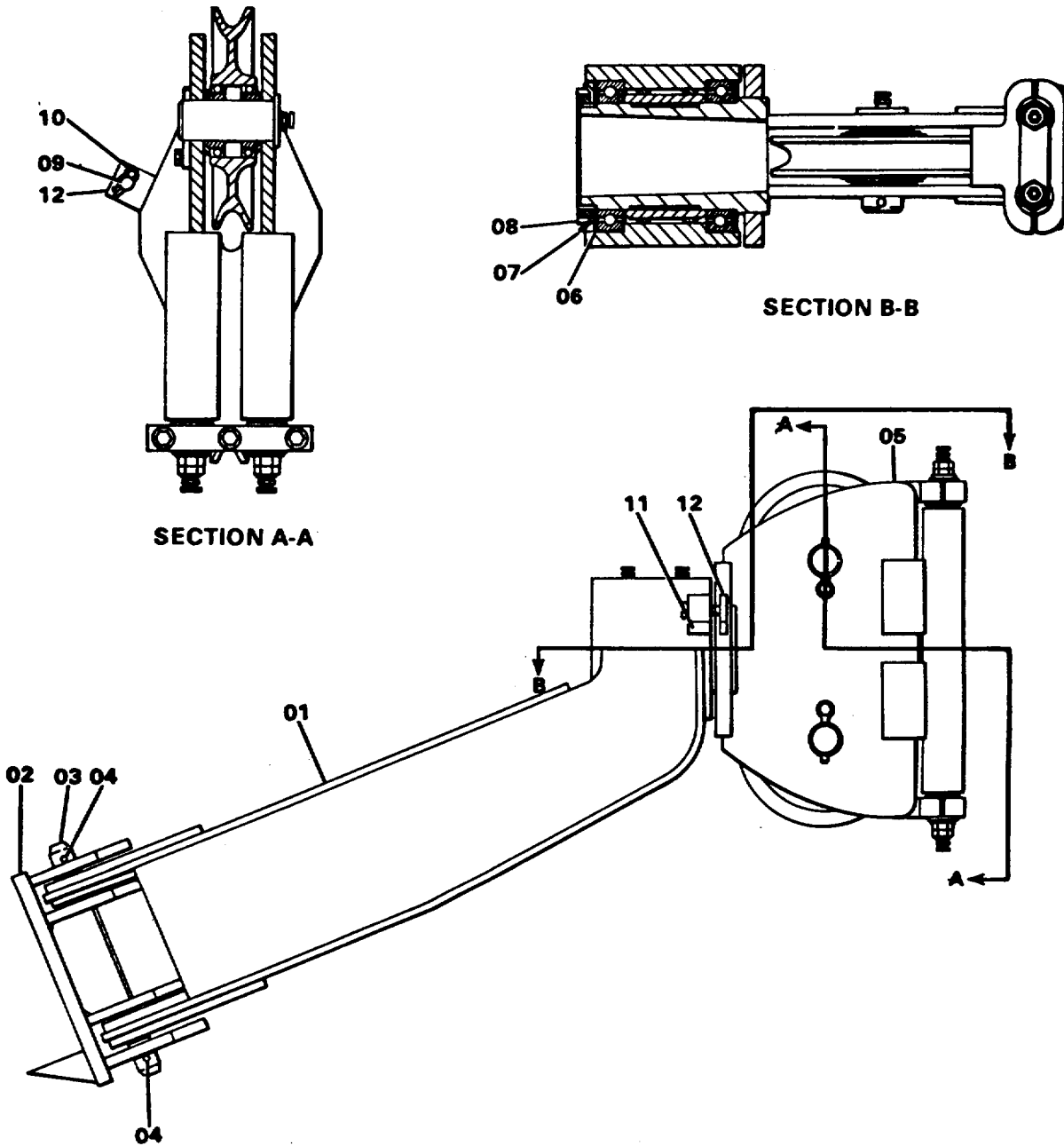

- 01. FAIRLEAD BRACKET
- 02. FRAME BRACKET
- 03. PIN
- 04. HAIR PIN
- 06. SHEAVE ASSEMBLY
- 06. BEARING RETAINER

- 07. LOCKWASHER
- 08. LOCKNUT
- 09. PIN
- 10. HAIR PIN
- 11. HEAD BLOCK
- 12. PLATE

Figure 2. Fairlead Installation and Removal

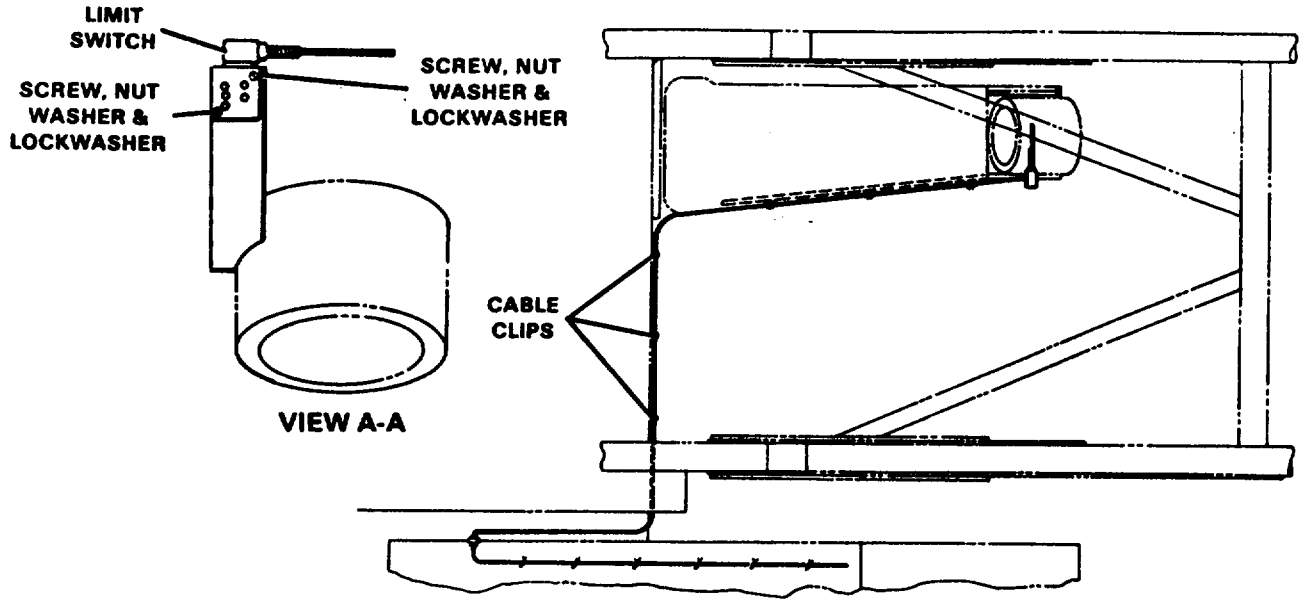

NOTE

See Figure 10A-1 of TM5-3810-303-24,

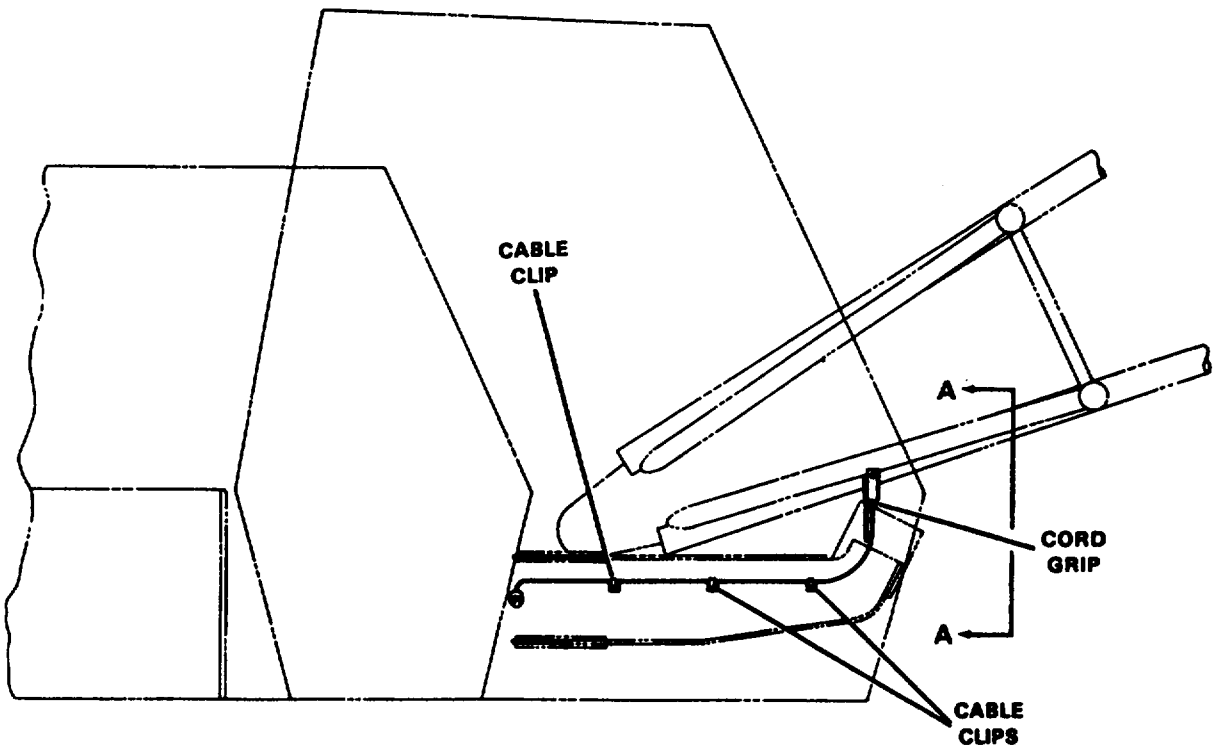
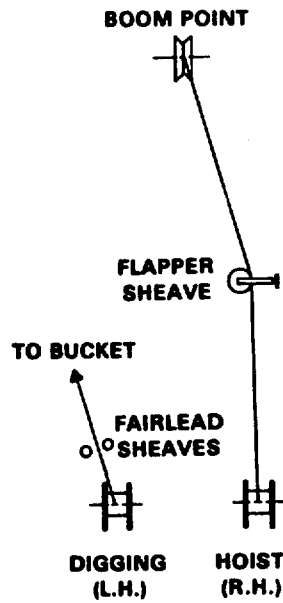

Figure 3. Fairlead Limit Switch



Boom Length	Right Hand Load Hoist Drum					
	Dragline (Hoist)			Clamshell (Holding)		
	Rope Size	Rope Type	1 Part	Rope Size	Rope Type	1 Part
22'						
25'						
50'			130'			115**
60'			140'			135**
70'						155**
80'						175**
90'						
100'	3/4"	25		3/4"	25	
110'						
120'						
130'						
140'						
150'						
160'						

Boom Length	Left Hand Load Hoist Drum					
	Dragline (Hoist)			Clamshell (Closing)		
	Rope Size	Rope Type	1 Part	Rope Size	Rope Type	1 Part
25'						
50'			65'			125'
60'			75'			145'
70'						165**
80'						185**
90'						
100'	7/8"	21A		3/4"	25	
110'						
120'						
130'						
140'						
150'						

*Rope will spool onto the second layer

Figure 4. Dragline Reeving

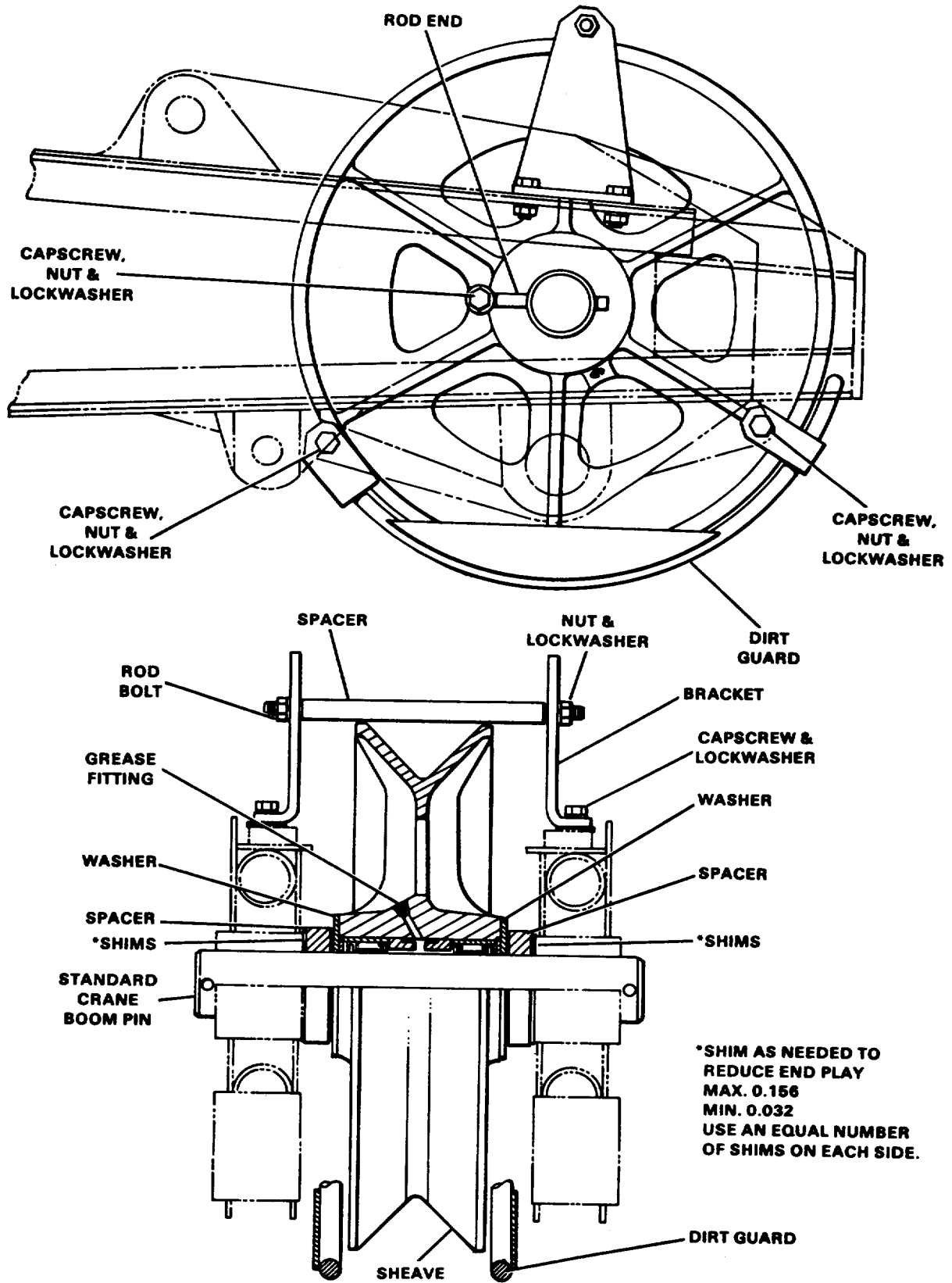
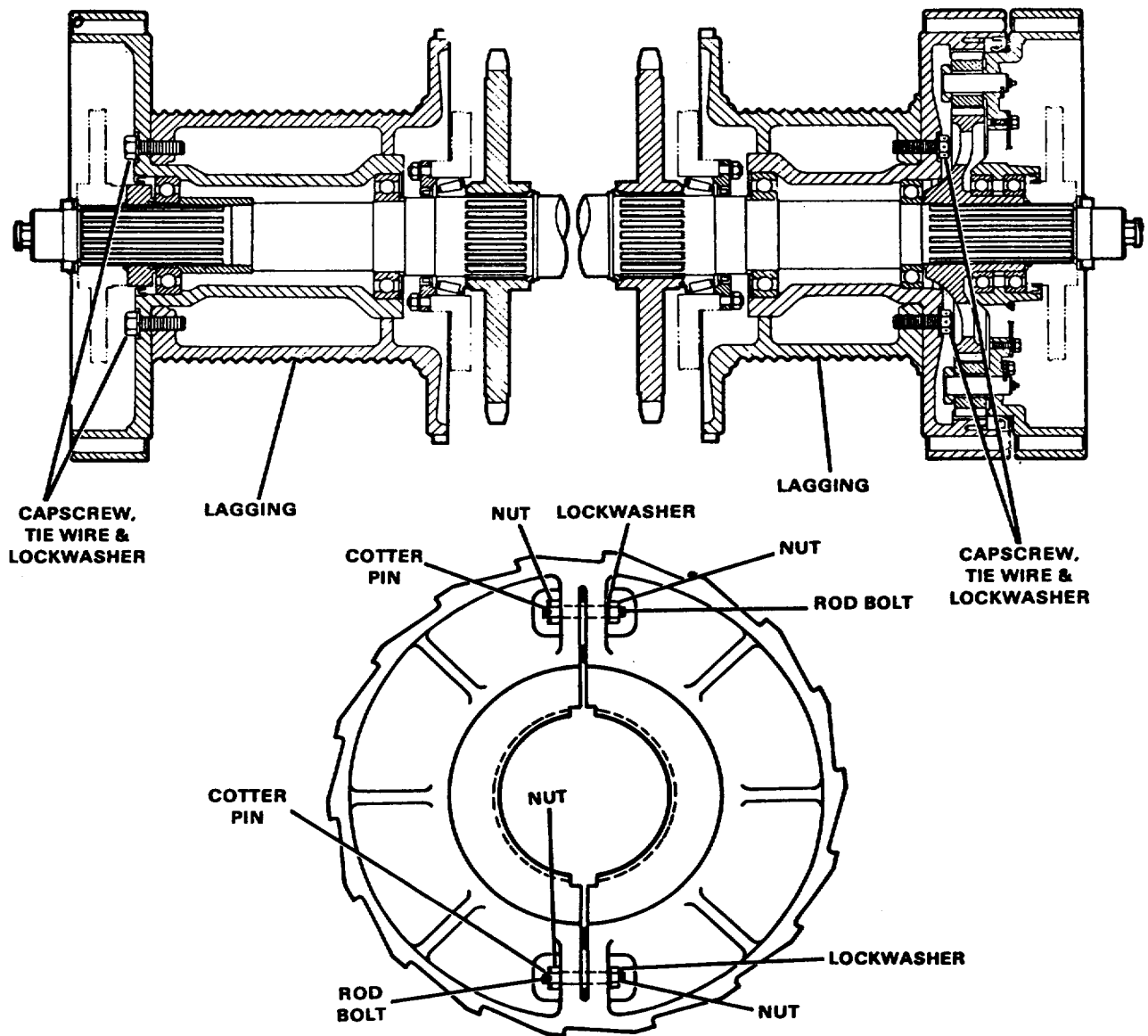

Figure 5. Dragline Boom Point



NOTE

Figure 6. Changing Lagging

Callouts below refer to Figure 9 on page 10.

1. Remove capscrews (01) and lockwashers (12). Remove nuts (02), lockstrap (03) and washers (04).
2. Drive pin (05) from roller (06) and supports (07). Remove roller (06).
3. Remove bearing retainer (08), felt closure (09) and bearings (10) from roller.
4. Remove and replace (if necessary) bushing (11) from support (07). Reinstall bushing (11) into support (07).
5. Inspect bearings (10) and replace if necessary.
6. Install bearings (10), felt closure (09) and bearing

- retainers (08) in roller (06).
7. Set roller up between supports (07) and install pin (05).
8. Install washers(04), nuts(02) and lockstrap (03). Tighten nuts (02) to remove all end play. Rollers should turn free after adjustment. Bend up, jockstraps (03) after adjusting.
9. Install capscrews (01) and lockwashers (12).
10. Lubricate rollers with GAA grease,

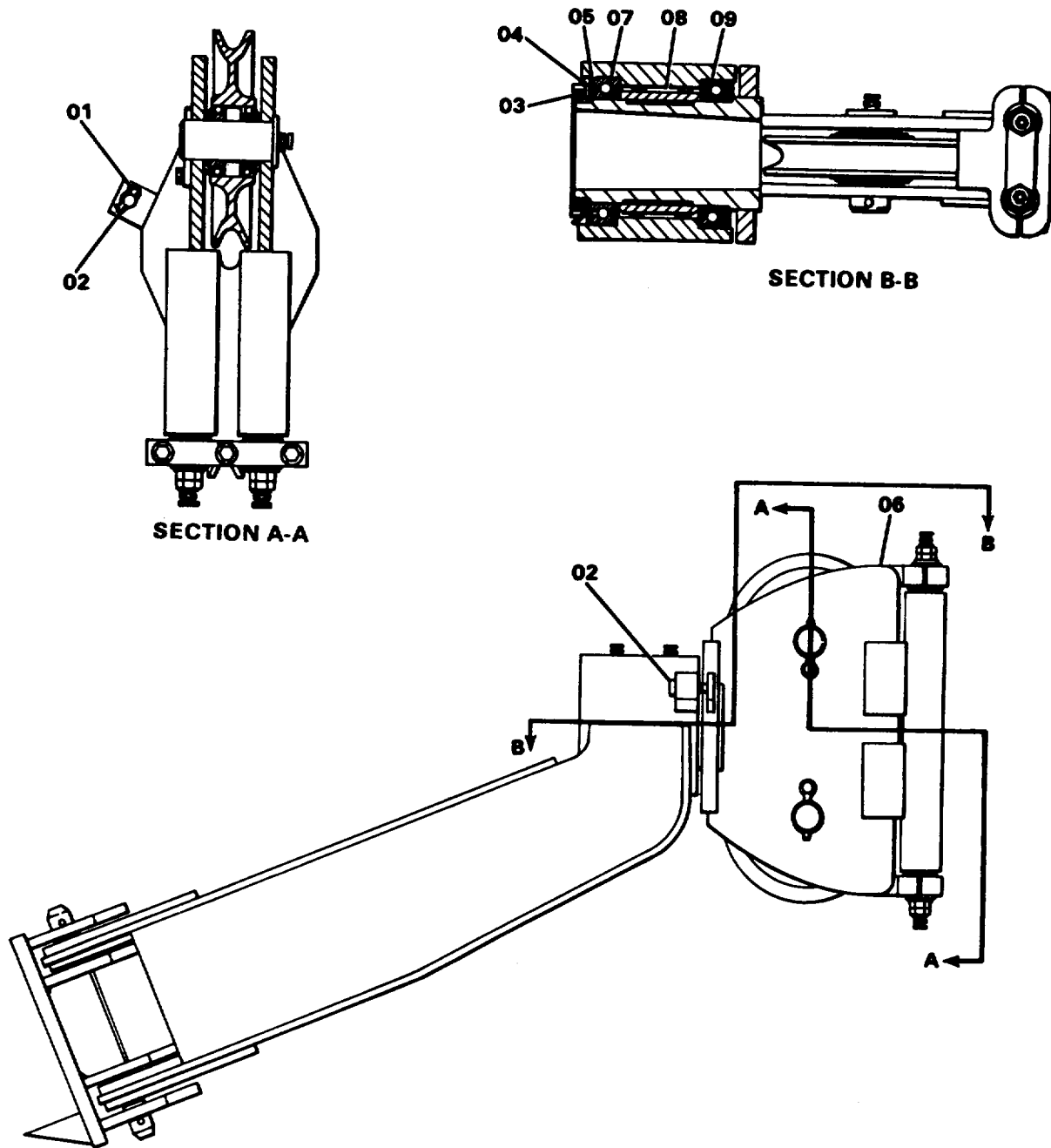

- | | |
|----------------------|----------------------|
| 01. HAIR PIN | 06. SHEAVE ASSEMBLY |
| 02. PIN | 07. BEARING |
| 03. LOCKNUT | 08. SPACER |
| 04. LOCKWASHER | 09. BEARING |
| 05. BEARING RETAINER | 10. BEARING RETAINER |

Figure 7. Fairlead Shaft Bearings

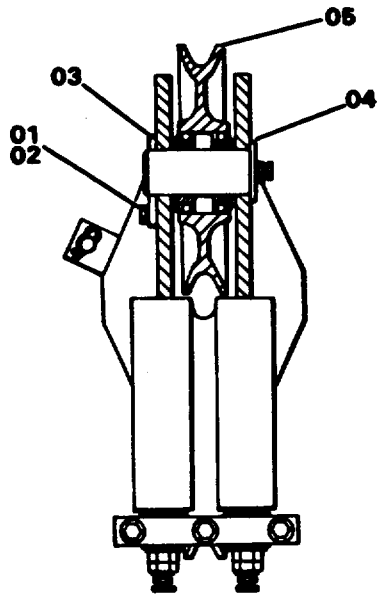

SECTION A-A

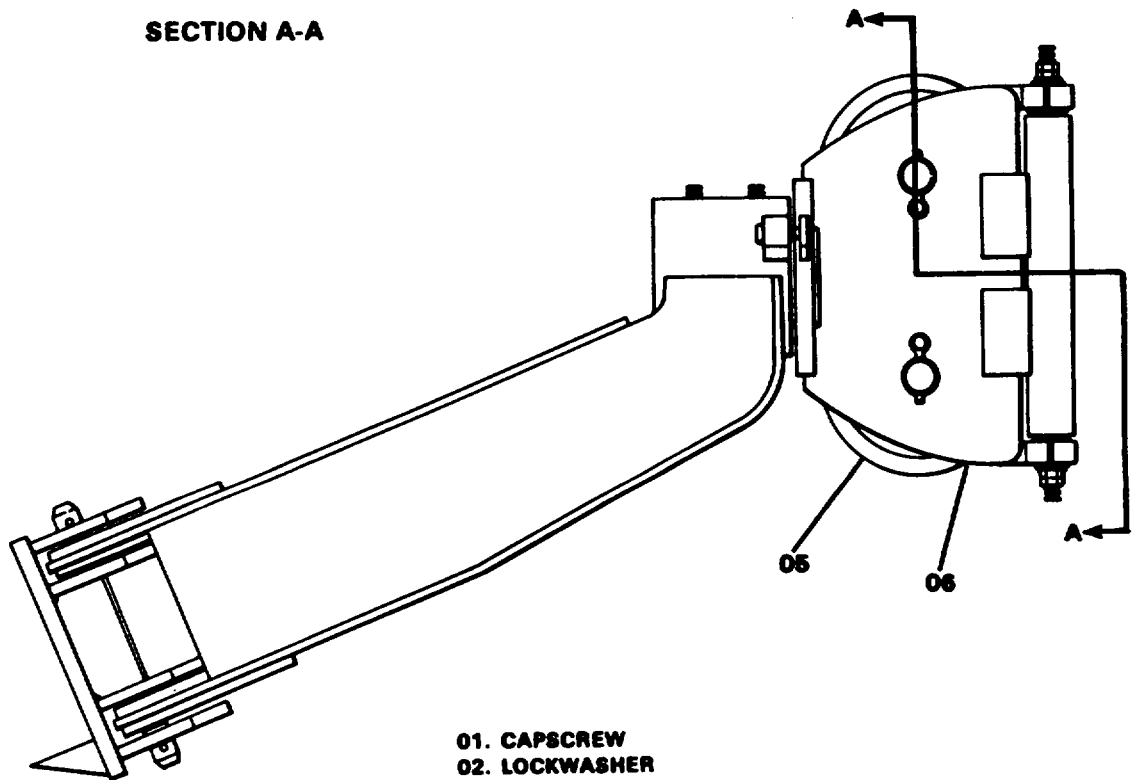

- 01. CAPSCREW**
- 02. LOCKWASHER**
- 03. ROD END**
- 04. PIN**
- 05. SHEAVE**
- 06. SHEAVE ASSEMBLY**

Figure 8. Sheave Replacement

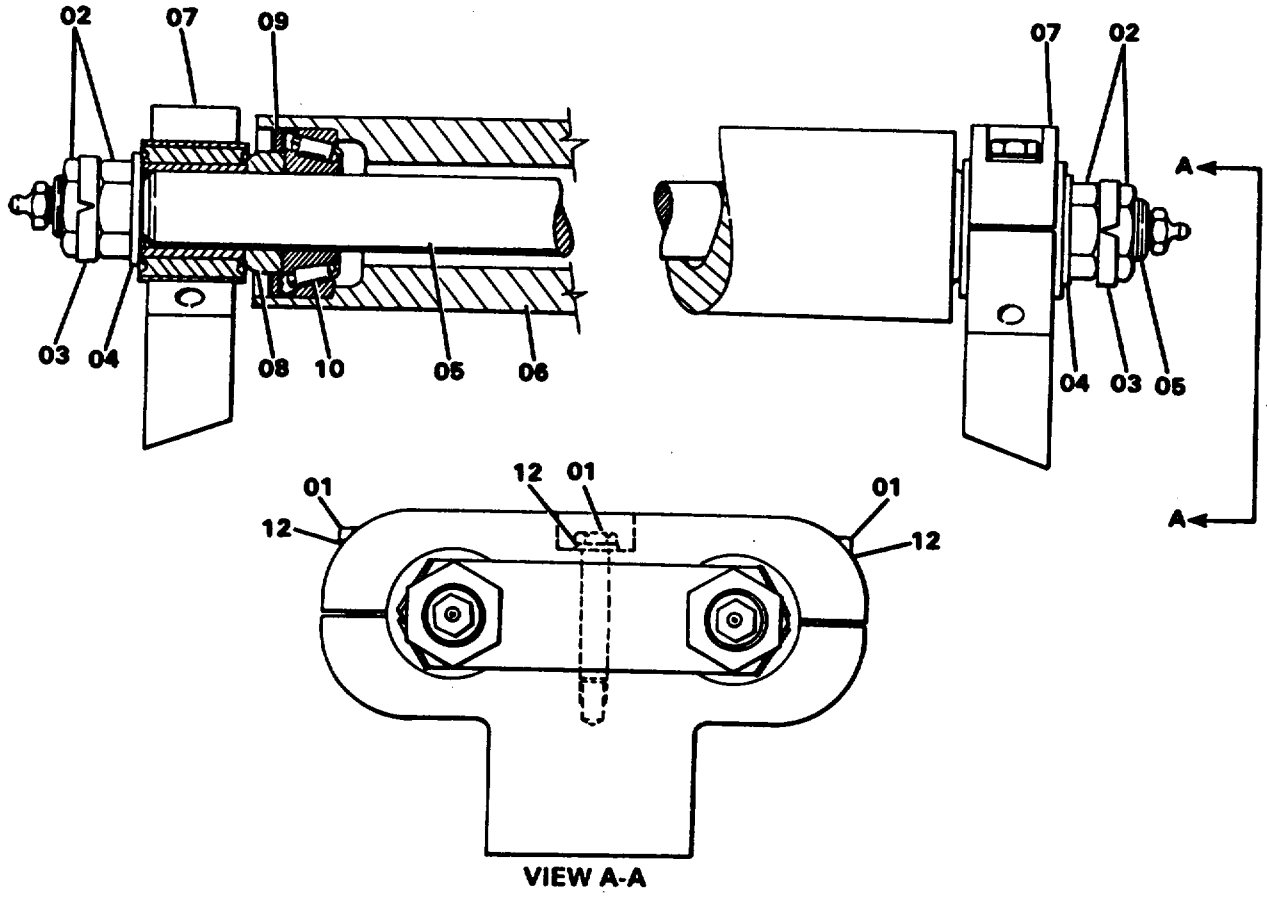

- | | |
|----------------------|-----------------------------|
| 01. CAPSCREW | 07. SUPPORT |
| 02. NUT | 08. BEARING RETAINER |
| 03. LOCKSTRAP | 09. FELT CLOSURE |
| 04. WASHER | 10. BEARING |
| 05. PIN | 11. BUSHING |
| 06. ROLLER | |

Figure 9. Roller Assembly

APPENDIX A

REFERENCES

A-1. SCOPE

This appendix lists Army regulations, forms, field manuals, technical manuals and other publications referenced in this manual and which apply to Operator, Unit, DS and GS maintenance of the Fairlead and Laggings.

A-2. ARMY REGULATIONS

Reporting of Transportation Discrepancies in Shipments AR 55-38
 Department of the Army Information Security Program AR 380-5

A-3. DEPARTMENT OF THE ARMY PAMPHLETS

Consolidated Index of Army Publications and Blank Forms..... DA Pam 25-30
 The Army Maintenance Management System (TAMMS)..... DA Pam 738-750
 U.S. Army Equipment Index of Modification Work Orders DA Pam 750-10

A-4. FORMS

U.S. Army Accident Investigation Report DA Form 285
 Equipment Operator's Qualifications Record (Except Aircraft) DA Form 348
 Recommended Changes to Publications and Blank Forms DA Form 2028
 Recommended Changes to Equipment Technical Manuals DA Form 2028-2
 Organizational Control Record for Equipment DA Form 2401
 Equipment Inspection and Maintenance Worksheet DA Form 2404
 Maintenance Request..... DA Form 2407
 Preventive Maintenance Schedule and Record DD Form 314
 Processing and Deprocessing Record for Shipment, Storage, and Issue
 of Vehicles and Spare Engines..... DD Form 1397
 DOD Fire Incident Report..... DD Form 2324
 U.S. Government Motor Vehicle Operator's Identification Card OF Form 346
 Operator's Report on Motor Vehicle Accident..... SF Form 91
 Transportation Discrepancy Report..... SF Form 361
 Report of Discrepancy (ROD) SF Form 364
 Product Quality Deficiency Report (7540-00-105-0078) SF Form 368

A-5. FIELD MANUALS

Camouflage FM 5-20
 Vehicle Recovery Operations FM 20-22
 First Aid for Soldiers FM 21-11
 Visual Signals FM 21-60
 Basic Cold Weather Manual FM 31-70
 Northern Operations FM 31-71
 Desert Operations FM 90-3

A-6. TECHNICAL BULLETINS

Occupational and Environmental Health: Hearing Conversation TB MED 501
 Solder and Soldering TB SIG 222
 Equipment Improvement Report and Maintenance Digest (U.S. Army
 Tank-Automotive Command) Tank-Automotive Equipment TB 43-0001-39 series
 Color, Marking, and Camouflage Painting of Military Vehicles, Construction
 Equipment, and Materials Handling Equipment TB 43-0209
 Maintenance in the Desert TB 43-0239
 Use of Antifreeze Solutions and Cleaning Compounds in Engine Cooling Systems TB 750-651

A-7. TECHNICAL MANUALS

Operator, Unit, Direct Support and General Support Maintenance Manual
 (Including Repair Parts and Special Tools List) Backhoe, 2 Yards Capacity
 (3815-01-153-1867) TM 5-3815-221-14&P
 Operator, Unit, Direct Support and General Support Maintenance Manual
 (Including Repair Parts and Special Tools List): Shovel Front,
 2 Yards Capacity (3815-01-153-1855) TM 5-3815-222-14&P
 Operator, Unit, Direct Support and General Support Maintenance Manual
 (Including Repair Parts and Special Tools List):
 Inserts and Jib (3815-01-153-1847) and (3815-01-153-1853) TM 5-3815-224-14&P
 Operator Maintenance Manual for 40 Ton Crane Crawler, Model 5060 TM 5-3810-303-10
 Unit, Direct Support and General Support Maintenance Manual for
 40 Ton Crane, Crawler, Model 5060 TM 5-3810-303-24
 Repair Parts and Special Tools List (Including Depot) for 40 Ton Crane Crawler,
 Model 5060 TM 5-381 0-303-24P
 Organizational Maintenance Manual: Night Vision Goggles, AN/PVS-5
 and AN/PVS-5A (5855-00-150-1820) TM 11-5855-238-20
 Organizational, Direct support and General Support Maintenance Manual,
 Including Depot Maintenance Repair Parts And Special Tools),
 Night Vision Goggles AN/PVS-5 and AN-PVS-5A (5855-00-150-1820) TM 11-5855-238-24&P
 Operator's, Organizational, Direct Support and General Support Maintenance
 Manual, Multimeter, Digital AN/PSM-45 (6625-01-139-2512) TM 11-6625-3052-14
 Army Equipment Data Sheets: Chemical Defense Equipment
 (Reprinted with Basic INCL-1) TM 43-0001-26-1
 Painting Instructions for Field Use TM 43-0139
 Procedures for Destruction of Tank-Automotive Equipment to Prevent Enemy Use TM 750-244-6
 Cooling Systems: Tactical Vehicles TM 750-254

A-8. OTHER PUBLICATIONS

Army Medical Department Expendable/Durable Items CTA 8-100
Expendable/Durable Items (Except Medical, Class V, Repair Parts, and Heraldic Items)..... CTA 50-970
Catalog of Audiovisual Productions, Army Productions, Volume I (PA)..... DOD5040.2-C-1

APPENDIX B. - SUPPLEMENTAL OPERATING AND MAINTENANCE INSTRUCTIONS**MAINTENANCE**

1. **MAINTENANCE CONCEPT:** Operators shall possess an MOS of 62F and maintenance will be performed by a 62B MOS. This is a Non-Developmental Item (NDI) and as such, there is no maintenance engineering effort on the part of the Army. However, consistent with maintenance policy and procedures of Preventive Maintenance Checks and Services (PMCS) and Maintenance Allocation Charts (MAC), the level of repair assigned to maintenance and associated tasks identified in the MAC should be reflective of training and repair part support for similar items of equipment in the inventory for unit through depot maintenance. Maintenance will be performed at the level authorized by the MAC and TOE/MTOE mission statements.

2. **MAINTENANCE PLAN:** Maintenance capabilities will be governed by the MAC and will be tailored to accommodate the complexity of the maintenance requirement.

a. **UNIT MAINTENANCE:** Unit Maintenance is performed by the operator, a crew or unit maintenance personnel as shown in the MAC of the appropriate TM, commercial manual or this publication. Unit Maintenance normally includes inspection by sight and touch of easily accessible components including; lubrication, cleaning, preserving, tightening, repair/replacement of parts (generally within two hours) and fault isolation using Built in Test/Built in Test Equipment (BIT/BITE), modularity and discard of components and selected items.

b. **DIRECT SUPPORT (DS):** Direct Support Maintenance is characterized by highly mobile forward orientation to remove, repair/replace unserviceable major assemblies and components. Direct support will provide contact maintenance teams for local support of unit maintenance support. DS personnel shall be capable of diagnosing causes of equipment failures, repairing specified components and repair parts, and returning the serviceable asset to the supply or reparable exchange (RX) system. DS may maintain a supply support system which allows unit maintenance to obtain repair parts through Reparable Exchange (RX) or requisitions. DS may operate an Operational Readiness Float system (ORF) for support units.

3. **MAINTENANCE ALLOCATION CHART (MAC):** Maintenance will be performed by the category (level) indicated on the Maintenance Allocation Chart to restore equipment to a fully mission capable serviceable condition. Higher levels of maintenance will perform lower level maintenance functions when required by appropriate commanders. Using/support maintenance activities may exceed their authorized level of maintenance when authorized by higher maintenance level commanders.
4. **MODIFICATION:** Modifications will be accomplished by the end item manufacturer after TACOM approves the field campaign or modification plan. Modification Work Orders (MWOs) will be complied with IAW AR 750-1, Paragraph 3-6.
5. **EQUIPMENT IMPROVEMENT RECOMMENDATIONS (EIR), AND QUALITY DEFICIENCY REPORT (QDR):** An EIR or QDR will be submitted IAW AR 750-1, Paragraph 3-42, and DA PAM 738-750, Chapter 12, Paragraph 12-1.
6. **SHIPMENT AND STORAGE:** Refer to the manufacturer's operating instructions, service manual and TB 740-97-2.
7. **DESTRUCTION TO PREVENT ENEMY USE.** Refer to TM 750-244-3, for instructions governing destruction of equipment to prevent enemy use.
8. **SPECIAL TOOLS, BASIC ISSUE ITEMS, ADDITIONAL AUTHORIZED ITEMS AND MAINTENANCE AND OPERATING SUPPLIES LISTS MAY BE FOUND IN THE APPENDIXES.**
9. **MAINTENANCE FORMS AND RECORDS:**
 - a Equipment Record Folder, NSN 7510-01-065-0166
 - b SF 91 and DD 518, Accident Forms
 - c DD 1970, Motor Equipment Utilization Record (Dispatch)
 - d DA 2401, Organizational Control Record for Equipment
 - e DA 2402, Exchange Tag
 - f DD 314, Preventive Maintenance Schedule and Record

g. DA 2404, Equipment Inspection and Maintenance Worksheet.

h. DA 2405, Maintenance Request Register

i. DA 2407 and DA 5504, Maintenance Request

j. DA 2407-1, Maintenance Request Extension Sheet

k. DA 2408-14, Uncorrected Fault Record

l. DA 3999-4, Maintenance Work Request Envelope

m. DA 5409, Inoperative Equipment Report

n. DA 5410, Unit Level Deadlining Parts Report

o. DA 5504, Maintenance Request

p. DA 5504-1, Maintenance Request continuation sheet

10. HISTORICAL RECORDS:

a. DA 2408-5, Equipment Modification Record

b. DA 2408-9, Equipment Control Record

c. DA 2408-20, Oil Analysis Log

d. DA 2409, Equipment Maintenance Log

e. Equipment Log Book Binder, NSN 7510-00-889-3494

11. LUBRICATION: To insure proper operation of this equipment, all points requiring lubrication must be serviced with correct lubrication, at the time interval specified on the Lubrication Chart.

12. PREVENTIVE MAINTENANCE CHECKS AND SERVICES (PMCS):
Perform PMCS IAW Appendix B.

13. MIXTURE OF INCH AND METRIC FASTENERS:

a. The use of world wide sources for components has made it possible to have a mixture of inch and metric fasteners. For example, metric fasteners may be used on some parts of a component, while not used on other parts of a component. It is possible that the internal bolts on a component may be metric, while the mounting bolts may be inch size.

b. To help mechanics know when metric fasteners are used on a product, future service publications such as parts books and operation/maintenance manuals will use a notice similar to the one that follows:

NOTICE

CAUTION MUST BE TAKEN TO AVOID MIXING METRIC AND INCH (CUSTOMARY) FASTENERS. MISMATCHED OR INCORRECT FASTENERS CAN RESULT IN EQUIPMENT DAMAGE OR MALFUNCTION, OR POSSIBLE PERSONAL INJURY. ORIGINAL FASTENERS REMOVED FROM THE VEHICLE SHOULD BE SAVED FOR ASSEMBLY WHEN POSSIBLE. IF NEW FASTENERS ARE REQUIRED, CAUTION MUST BE TAKEN TO REPLACE THE FASTENER WITH ONE THAT IS OF THE SAME SPECIFICATIONS (SIZE/GRADE) AS THE ORIGINAL.

c. To convert inches to millimeters, or millimeters to inches, see The Metric System And Equivalents (inside back cover).

MAINTENANCE ALLOCATION CHART
FOR
FAIRLEAD AND LAGGINGS
NSN 3815-01-153-1861

1. General: This Maintenance Allocation Chart designates responsibility for performance of Maintenance functions to specific Maintenance categories.

2. Maintenance Functions:

a. Inspect: To determine the serviceability of an item by comparing its physical, mechanical and/or electrical characteristics with established standards through examination.

b. Test: To verify serviceability and detect incipient failures by measuring the mechanical or electrical characteristics of an item and comparing those characteristics with prescribed standards.

c. Service: Operations required periodically to keep an item in proper operating condition, i.e., to clean (decontaminate), to preserve, to drain, to paint, or to replenish fuel, lubricants, hydraulic fluids, or compressed air supplies.

d. Adjust: To maintain, within prescribed limits, by bringing into proper or exact position, or by setting the operating characteristics to specified parameters.

e. Align: To adjust specified variable elements of an item to bring about optimum or desired performance.

f. Calibrate: To determine and cause corrections to be made or to be adjusted on instruments or test measuring and diagnostic equipment used in precision measurement. Consists of comparisons of two instruments, one of which is a certified standard of known accuracy, - to detect and adjust any discrepancy in the accuracy of the instrument being compared.

g. Install: The act of emplacing, seating, or fixing into position an item, part, or module (component or assembly) in a manner to allow the proper functioning of an equipment or system.

h. Replace: The act of substituting a serviceable like type part, subassembly, or module (component or assembly) for an unserviceable counter- part.

i. Repair: The application of maintenance services or other maintenance actions to restore serviceability to an item by correcting specific damage, fault, malfunction, or failure in a part, subassembly, module (component or assembly), end item, or system.

3. Column Entries: Columns used in the Maintenance Allocation Chart are explained below:

a. Column 1, Group Number: Column 1 lists group numbers, the purpose of which is to identify components, assemblies, subassemblies, and modules with the next Higher assembly.

b. Column 2, Component/Assembly: Column 2 contains the noun names of components, assemblies, subassemblies, and modules for which maintenance is authorized.

c. Column 3, Maintenance Functions: Column 3 lists the functions to be performed on the item listed in Column 2.

d. Column 4, Maintenance Category: Column 4 specifies, by the listing of a "work time" figure in the appropriate subcolumn(s), the lowest level of maintenance authorized to perform the function listed in Column 3. This figure represents the active time required to perform that maintenance function at the indicated category of maintenance. If the number or complexity of the tasks within the listed maintenance function vary at different maintenance categories, appropriate "work time" figures will be shown for each category. The number of man-hours specified by the "work time" figure represents the average time required to restore an item (assembly, subassembly, component, module, end item or system) to a serviceable condition under typical field operating conditions. This time includes preparation time, troubleshooting time, and quality assurance/quality control time in addition to the time required to perform the specific tasks identified for the maintenance functions authorized in the Maintenance Allocation Chart.

e. Column 5, Tools and Equipment: Column 5 specifies by code, those common tool sets (not individual tools) and special tools, test, and support equipment required to perform the designated function.

f. Column 6, Remarks: Column 6 contains an alphabetic code which leads to the remark in Section IV, Remarks, which is pertinent to the item opposite the particular code.

SECTION II. MAINTENANCE ALLOCATION CHART

GROUP NUMBER (1)	COMPONENT/ASSEMBLY (2)	MAINTENANCE FUNCTION (3)	MAINT CAT* (4)					TOOLS & EQUIP (5)	REMARKS (6)
			C	O	F	H	D		
74	Cranes, Shovels and Earthmoving Components								
7411	Crane, Dragline or Clamshell Attachments								
	Fairlead Assembly								
	Grooved Pulley	Inspect Replace Repair	0.1	2.0 1.0					
	Pawls	Inspect Replace	0.1	0.8					
	Limit Switch	Inspect Replace	0.1	0.8					
	Bearing	Inspect Replace		0.1 1.0					
	Lagging & Drum Assembly								
	Lagging	Inspect Replace	0.1	2.0					
	Drum	Inspect Replace Repair	0.1	2.0	4.0				
	Wire Rope	Inspect Replace	0.1	2.0					
	Boom Point Assembly								
	Sheave	Inspect Replace Repair	0.1	2.0					

*MAINTENANCE CATEGORIES:
C - OPERATOR/CREW
O - ORGANIZATIONAL

F - DIRECT SUPPORT
H - GENERAL SUPPORT
D - DEPOT

TA FORM 668-1
 1 NOV 83

OPERATOR/CREW
PREVENTIVE MAINTENANCE CHECKS AND SERVICES (PMCS)

GENERAL

Your Preventive Maintenance Checks and Service table lists the inspection and care of your equipment required to keep it in good operating condition.

OPERATOR/CREW PREVENTIVE MAINTENANCE CHECKS AND SERVICES

1. The number column of your PMCS is the source for the number used on the TM number column on DA Form 2404.
2. The interval column of your PMCS table tells you when to do a certain check or service.
 - a. Before you operate. Always keep in mind the WARNINGS and CAUTIONS. Perform your before (B) PMCS.
 - b. While you operate. Always keep in mind the WARNINGS and CAUTIONS. Perform your during (D) PMCS.
 - c. After you operate. Be sure to perform your after (A) PMCS.
 - d. Do your weekly (W) PMCS once a month.
3. The procedure column of your PMCS table tells you how to do the required checks and services. Carefully follow these instructions. If you do not have the tools, or if the procedure tells you to, contact unit maintenance.
4. If your equipment does not perform as required, refer to the manual troubleshooting section for possible problems. Report any malfunctions or failures on the proper DA Form 2404 or refer to DA Pamphlet 738-750.

NOTE

The terms ready/available and mission capable refer to the same status: Equipment is on hand and is able to perform all its combat missions without further endangering the lives of crew or operators in a combat environment (See DA Pamphlet 738-750.

5. Equipment is not ready/available if: column. This column tells you when and why your equipment cannot be used.
6. Always do your PMCS in the same order so it gets to be a habit. Once you've had some practice, you'll spot anything wrong in a hurry.

7. When you do your PMCS, take along a rag or two.
8. While performing PMCS, observe WARNING and CAUTIONS preceding those operations which could endanger your safety or result in damage to the equipment.

WARNING

Dry cleaning solvent P-D-680 is toxic and flammable. wear protective goggles and gloves and use only in a well ventilated area. Avoid contact with skin, eyes, and clothes and don't breathe vapors. Do not use near open flame or excessive heat. The flash point is 100 F - 138 F (38 C - 590C). If you become dizzy while using cleaning solvent, get fresh air immediately and get medical aid. If contact with eyes is made, wash your eyes with water and get medical aid immediately.

- a. Keep it clean; dirt, grease, oil and debris only get in the way and may cover up a serious problem. Clean as you work and as needed. Use dry cleaning solvent (P-D-680) to clean metal surfaces. Use soap and water when you clean rubber or plastic material.
- b. Bolts, nuts, and screws: check that they are not loose, missing, bent or broken. You can't try them all with a tool, of course, but look for chipped paint, bare metal or rust around bolt heads. Tighten any bolt, nut, or screw that you find loose.
- c. Welds: Look for loose or chipped paint, rust or gaps where parts are welded together. If you find a bad weld, report it to unit maintenance.
- d. Electric wires and connectors: Look for cracked or broken insulation, bare wires and loose or broken connectors. Report damaged or loose wiring to unit maintenance.
- e. Hoses and fluid lines: Look for wear, damage and leaks. Make sure clamps and fittings are tight. Wet spots show leaks but a stain around a fitting or connector can also mean a leak. If leakage comes from a loose fitting or connector, tighten the fitting or connector. If something is broken or worn out, report it to unit maintenance.
- f. Vehicle must be on level ground in order to get correct fluid level measurement.

It is necessary for you to know how leaks affect the status of your equipment. The following are definitions of the types/classes of leakage you need to know to be able to determine the status of your equipment. Learn and be familiar with them and REMEMBER - when in doubt, notify your supervisor.

LEAKAGE DEFINITIONS FOR OPERATOR/CREW PMCS

- | | | |
|----------------|-----|---|
| CLASS | I | Seepage of fluid (as indicated by wetness or discoloration) not great enough to form drops. |
| CLASS
being | II | Leakage of fluid great enough to form drops, but not enough to cause drops to drip from the item checked/inspected. |
| CLASS | III | Leakage of fluid great enough to form drops that fall from the item being checked/inspected. |

CAUTION

Equipment operation is allowable with minor leakage (Class I or II). Of course, consideration must be given to the fluid capacity in the item/system being checks/inspected. When operating with Class I or II leaks, continue to check fluid levels as required on your PMCS. Class II leaks should be reported to your supervisor or unit maintenance.

OPERATOR/CREW PREVENTIVE MAINTENANCE CHECKS AND SERVICES

B - BEFORE D - DURING A - AFTER W - WEEKLY M - MONTHLY

ITEM NO	INTERVAL					ITEM TO BE INSPECTED PROCEDURE:CHECK FOR AND HAVE REPAIRED, FILLED, OR ADJUSTED AS NEEDED	EQUIPMENT IS NOT READY/AVAILABLE IF:
	B	D	A	W	M		
1	X	X X				FAIRLEAD ASSEMBLY - Check for cracked welds or damaged sheaves. Check for ease of operation. Check limit switch for proper operation	Fairlead binds. Inop limit switch.
2	X	X				LAGGING AND DRUM ASSEMBLY - Check for broken teeth on the lagging. Check for ease of operation.	Two or more broken teeth.
<p><u>WARNING</u></p> <p>Use leather gloves when handling wire rope</p>							
3	X					WIRE ROPE - Check for damaged wire rope.	See Appendix for wire rope standards and NMC Conditions
4	X					BOOM POINT ASSEMBLY - Visually check for wear on the sheave and bearing,	

UNIT
PREVENTIVE MAINTENANCE CHECKS AND SERVICES (PMCS)

GENERAL

To make sure that your vehicle is ready for operation at all times, inspect it systematically so you can discover any defects and have them corrected before they result in serious damage or failure. The charts on the next few pages contain your unit PMCS. The item numbers indicate the sequence of minimum inspection requirements. If you're operating the vehicle and notice something wrong which could damage the equipment if you continue operation, stop operation immediately.

Record all deficiencies and shortcomings, along with the corrective action taken on a DA Form 2404. The Item Number column is the source for the numbers used on the TM Number column on DA Form 2404.

UNIT PREVENTIVE MAINTENANCE CHECKS AND SERVICES

1. The item numbers of the table indicate the sequence of the PMCS. Perform at the intervals shown below:
 - a. Do your (Q) PREVENTIVE MAINTENANCE quarterly (every three months).
 - b. Do your (S) PREVENTIVE MAINTENANCE semiannually (every six months) .
 - c. Do your (A) PREVENTIVE MAINTENANCE annually (once every year).
 - d. Do your (B) PREVENTIVE MAINTENANCE biennially (one every two years).
 - e. Do your (H) PREVENTIVE MAINTENANCE at the hour interval listed.
 - f. Do your (MI) PREVENTIVE MAINTENANCE at the mile interval listed.
2. If something doesn't work, troubleshoot it according to the instructions in this manual or the commercial manual or notify your supervisor.
3. Always do your preventive maintenance in the same order so it gets to be a habit. Once you've had some practice, you'll spot anything wrong in a hurry.

4. If anything looks wrong and you can't fix it, write it down on your DA Form 2404. If you find something seriously wrong, report it to direct support as soon as possible.

WARNING

Dry cleaning solvent P-D-680 is toxic and flammable. Wear protective goggles and gloves and use only in a well ventilated area. Avoid contact with skin, eyes, and clothes and don't breathe vapors. Do not use near open flame or excessive heat. The flash point is 1000F 1380F (38 C 590C). If you become dizzy while using cleaning solvent, get fresh air immediately and get medical aid. If contact with eyes is made, wash your eyes with water and get medical aid immediately.

WARNING

Compressed air, used for cleaning purposes will not exceed 30 psi. Use only with effective chip guarding and personnel protective equipment (goggles/shield/gloves, etc.).

a. Keep it clean: dirt, grease, oil, and debris only get in the way and may cover up a serious problem. Clean as you work and as needed. Use dry cleaning solvent (P-D-680) to clean metal surfaced. Use soap and water when you clean rubber or plastic material.

b. Bolts, nuts and screws: check that they are not loose, missing, bent, or broken. You can't try them all with a tool, of course, but look for chipped paint, bare metal or rust around bolt heads. Tighten any bolt, nut, or screw that you find loose.

c. Welds: look for loose or chipped paint, rust or gaps where parts are welded together. If you find a bad weld, report it to intermediate direct support.

d. Electric wires and connectors: look for cracked or broken insulation, bare wires and loose or broken connectors. Tighten loose connections and make sure the wires are in good condition.

e. Hoses and fluid lines: look for wear, damage and leaks. Make sure clamps and fittings are tight. Wet spots show leaks, but a stain around a fitting or connector can also mean a leak. If leakage comes from a loose fitting or connector, tighten the fitting or connector. If something is broken or worn out, either correct it or report it to intermediate direct support (refer to the Maintenance Allocation Chart).

5. It is necessary for you to know how fluid leaks affect the status of your equipment. The following are definitions of the types/classes of leakage you need to know to be able to determine the status of your equipment. Learn and be familiar with them and REMEMBER - when in doubt, notify your supervisor.

LEAKAGE DEFINITIONS FOR UNIT PMCS

CLASS I Seepage of fluid (as indicated by wetness or discoloration) not great enough to form drops.

CLASS II Leakage of fluid great enough to form drops, but not enough to cause drops to drip from the item being checked/inspected.

CLASS III Leakage of fluid great enough to form drops that fall from the item being checked/inspected.

CAUTION

Equipment operation is allowable with minor leakage (Class I or II). Of course consideration must be given to the fluid capacity in the item/system being check/inspected. When operating with Class I or II leaks, continue to check fluid levels as required on your PMCS. Class II leaks should be reported to your supervisor or unit maintenance.

B-14

UNIT PREVENTIVE MAINTENANCE CHECKS AND SERVICES

M-MONTHLY Q-QUARTERLY S-SEMIANNUALLY A-ANNUALLY B-BIENNALLY H-HOURS MI-MILES

ITEM NO	INTERVAL						ITEM TO BE INSPECTED PROCEDURE: CHECK FOR AND HAVE REPAIRED, FILLED, OR ADJUSTED AS NEEDED
	M	Q	S	A	B	H	
1			X				FAIRLEAD ASSEMBLY - Check for worn bearing.
2			X				DRUM AND LAGGING - Check for damaged pawl.

EQUIPMENT PUBLICATIONS		
NOMENCLATURE	EQUIPMENT PUBLICATION NUMBER	DATE
Utilization of Construction Equipment	TM5-331B	May 68
Safe Use of Cranes, Crane Shovel, and Draglines	TB 385-101	Jan 71
Procedures for Licensing Operators of Construction Equipment	TB 600-2	Sep 78

OTHER THAN OFFICIAL DA EQUIPMENT PUBLICATIONS			
NOMENCLATURE	EQUIPMENT PUBLICATION NUMBER OR TYPE	DATE	SOURCE OF SUPPLY

APPENDIX C. - REPAIR PARTS AND SPECIAL TOOLS LIST OPERATOR, UNIT, DIRECT SUPPORT AND GENERAL SUPPORT MAINTENANCE REPAIR PARTS AND SPECIAL TOOLS LIST (INCLUDING DEPOT MAINTENANCE REPAIR PARTS AND SPECIAL TOOLS LIST)

SECTION I. INTRODUCTION

1. Scope.

This RPSTL lists and authorizes spares and repair parts, special tools, special test, measurement, and diagnostic equipment (TMDE), and other special support equipment required for performance of Operator, Unit Maintenance, Direct Support and General Support Maintenance of the Crane Fairlead and Laggings. It authorizes the requisitioning, issue, and disposition of spares, repair parts and special tools as indicated by the source, maintenance and recoverability (SMR) codes.

2. General.

In addition to Section I. Introduction, this Repair Parts and Special Tools List is divided into the following sections:

a. *Section II. Repair Parts List.* A list of spares and repair parts authorized by this RPSTL for use in the performance of maintenance. The list also includes parts which must be removed for replacement of the authorized parts. Parts lists are composed of functional groups in ascending alphanumeric sequence, with the parts in each group listed in ascending figure and item number sequence. Bulk materials are listed in item name sequence. Repair kits are listed separately in their own functional group within Section II. Repair parts for repairable special tools are also listed in the section. Items listed are shown on the associated illustration(s)/figure(s).

b. *Section III. Special Tools List.* A list of special tools, special TMDE, and other special support equipment authorized by this RPSTL (as indicated by Basis of Issue (BOI) information in DESCRIPTION AND USABLE ON CODE column) for the performance of maintenance.

c. *Section IV. Cross-reference Index.* A list, in National Item Identification Number (NIIN) sequence, of all National stock numbered items appearing in the listing, followed by a list in alphanumeric sequence of all part numbers appearing in the listings. National stock numbers and part numbers are cross-referenced to each illustration figure and item number appearance.

The figure and item number index lists figure and item numbers in alphanumeric sequence and cross-references NSN, CAGE, and part numbers.

3. Explanation of Columns (Sections II and III).

a. *ITEM NO. (Column (1)).* Indicates the number used to identify items called out in the illustration.

b. *SMR CODE (Column (2)).* The Source, Maintenance, and Recoverability (SMR) code is a 5-position code containing supply/requisitioning information, maintenance category authorization criteria, and disposition instructions, as shown in the following breakout:

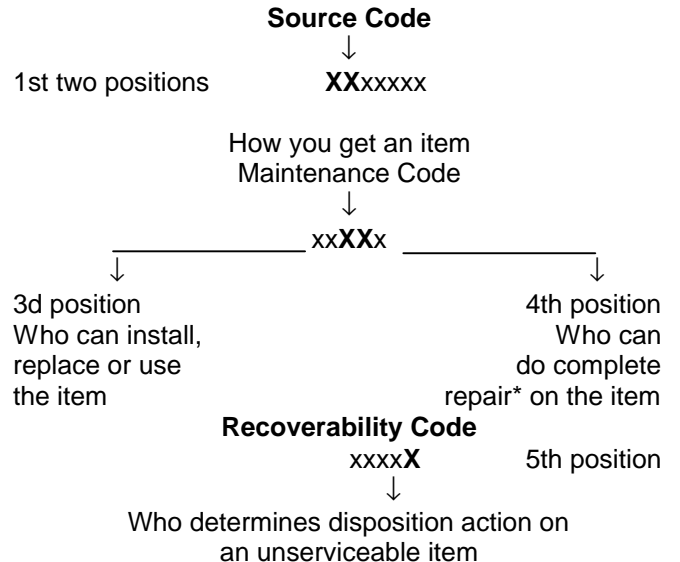

*Complete Repair: Maintenance capacity, capability, and authority to perform all corrective maintenance tasks of the "Repair" function in a use/user environment in order to restore serviceability to a failed item.

(1) Source Code. The source code tells you how to get an item needed for maintenance, repair, or overhaul of an end item/equipment. Explanations of source codes follows:

Code	Application/Explanation
PA	Stocked items; use the applicable NSN to request/requisition items with these source codes.
PB	They are authorized to the category indicated by the code entered in the 3d PE
PC**	**items coded PC are subject to deterioration.
PD	Items with these codes are not to be requested/requisitioned individually. They are part of a kit which is authorized to the maintenance category indicated in the 3d position of the SMR code. The complete kit must be requisitioned and applied.
PF	
PG	
KD	
KF	
KB	

MO-(Made at UM/AVUM Level)	Items with these codes are not to be requested/requisitioned individually. They must be made from bulk material which is identified by the part number in the DESCRIPTION AND USABLE ON CODE (UOC) column and listed in the Bulk Material group of the repair parts list in this RPSTL. If the item is authorized to you by the 3d position code of the SMR code, but the source code indicates it is made at a higher level, order the item from the higher level of maintenance.
MF-(Made at DS/AVUM Level)	
MH-(Made at GS)	
MH-(Made at GS)	
ML-(Made at Specialized Repair Act (SRA))	
MD-(Made at Depot)	

AO-(Assembled by UM/AVUM Level)	Items with these codes are not to be requested/requisitioned individually. The parts that make up the assembled item must be requisitioned or fabricated and assembled at the level of maintenance indicated by the source code. If the 3d position code of the SMR code authorizes you to replace the item, but the source code indicates the item is assembled at a higher level, order the item from the higher level of maintenance.
AF-(Assembled by DS/AVIM Level)	
AH-(Assembled by GS Category)	
AL-(Assembled by SRA)	
AD-(Assembled by Depot)	

Do not requisition an "XA"-coded item.

XA Order its next higher assembly. (Also, refer to the NOTE below.)

- XB - If an "XB" item is not available from salvage, order it using the CAGE and part number given.
- XC - Installation drawing, diagram, instruction sheet, field service drawing, that is identified by the manufacturer's part number.
- XD - Item is not stocked. Order an "XD"-coded item through normal supply channels using the position of the SMR code number given, if no NSN is available.

NOTE: Cannibalization or controlled exchange, when authorized, may be used as source of supply for items with the above source codes, except for those source coded "XA" or those aircraft support items restricted by requirements of AR 700-42.

(2) Maintenance Code. Maintenance codes tell you the level(s) of maintenance authorized to USE and REPAIR support items. The maintenance codes are entered in the third and fourth positions of the SMR Code as follows:

(a) The maintenance code entered in the third position tells you the lowest maintenance level authorized to remove, replace, and use an item. The maintenance code entered in the third position will indicate authorization to one of the following levels of maintenance.

Code	Explanation
O-	Unit maintenance or aviation unit category can remove, replace, and use the item.
F-	Intermediate direct support or aviation intermediate level can remove, replace, and use the item.
H-	Intermediate general support level can remove, replace, and use the item.
L-	Specialized repair activity can remove, replace, and use the item.
D-	Depot level can remove, replace, and use the item.

(b) The maintenance code entered in the fourth position tells whether or not the item is to be repaired and identifies the lowest maintenance level with the capability to do complete repair (i.e., perform all authorized repair functions.) (NOTE Some limited repair may be done on the item at a lower level of maintenance, if authorized by the Maintenance Allocation Chart (MAC) and SMR codes.) This position will contain one of the following maintenance codes:

Code	Application/Explanation
O-	Unit maintenance or aviation unit is the lowest level that can do complete repair of the item.
F-	Direct support or aviation is the lowest level that can do complete repair of the item.
H-	General support is the lowest level that can do complete repair of the item.
L-	Specialized repair activity is the lowest level that can do complete repair of the item.
D-	Depot is the lowest level that can do complete repair of the item.
Z-	Nonreparable. No repair is authorized.
B-	No repair is authorized. (No parts or special tools are authorized for the maintenance of a "B" coded item). However, the item may be reconditioned by adjusting, lubrication, etc., at the user level.

(3) *Recoverability Code.*

Recoverability codes are assigned to items to indicate the disposition action on unserviceable items. The recoverability code is entered in the fifth position of the SMR Code as follows:

<u>Code</u>	<u>Application/Explanation</u>
Z-	Nonreparable item. When unserviceable, condemn and dispose of the item at the level of maintenance shown in 3d position of SMR Code.
O-	Reparable item. When uneconomically repairable, condemn and dispose of the item at unit maintenance or aviation unit level.
F-	Reparable item. When uneconomically repairable, condemn and dispose of the item at the intermediate direct support or aviation intermediate level.
H-	Reparable item. When uneconomically repairable, condemn and dispose of the item at the intermediate general support level.
D-	Reparable item. When beyond lower level repair capability, return to depot. Condemnation and disposal of item not authorized below depot level.
L-	Reparable item. Condemnation and disposal of item not authorized below specialized repair activity (SRA).

A - Item requires special handling or condemnation procedures because of specific reasons (e.g., precious metal content, high dollar value, critical material, or hazardous material). Refer to appropriate manuals/directives for specific instructions.

c. *CAGE (Column 3)*. The Commercial and Governmental Entity (CAGE) Code (C) is a 5-digit numeric code which is used to identify the manufacturer, distributor, or Government agency, etc., that supplies the item.

d. *PART NUMBER (Column 4)*. Indicates the primary number used by the manufacturer (individual, company, firm, corporation, or Government activity), which controls the design and characteristics of the item by means of its engineering drawings, specifications standards, and inspection requirements to identify an item or range of items.

NOTE: When you use a NSN to requisition an item, the item you receive may have a different part number from the part ordered.

e. *DESCRIPTION AND USABLE ON CODE (UOC) (Column 5)*. This column includes the following information:

- (1) The Federal item name and, when required, a minimum description to identify the item.
- (2) Physical security classification. Not applicable
- (3) Items that are included in kits and sets are listed below the name of the kit or set on Figure KIT.
- (4) Spare/repair parts that make up an assembled item are listed immediately following the assembled item line entry.
- (5) Part numbers for bulk materials are referenced in this column in the line item entry for the item to be manufactured/fabricated.
- (6) When the item is not used with all serial numbers of the same model, the effective serial numbers are shown on the last line(s) of the description (before UOC). Not applicable.
- (7) The usable on code, when applicable (see paragraph 5, Special information)
- (8) In the Special Tools List section, the basis of issue (BOI) appears as the last line(s) in the entry for each special tool, special TMDE, and other special support equipment. When density of equipments supported exceeds density spread indicated in the basis of issue, the total authorization is increased proportionately.
- (9) The statement "END OF FIGURE" appears just below the last item description in Column 5 for a given figure in both Section II and Section III.

f. QTY (Column (6)). The QTY (quantity per figure column) indicates the quantity of the item used in the breakout shown on the illustration figure, which is prepared for a functional group, subfunctional group, or an assembly. A "V" appearing in this column in lieu of a quantity indicates that the quantity is variable and the quantity may vary from application to application.

4. Explanation of Columns (Section IV).

a. NATIONAL STOCK NUMBER (NSN) INDEX.

(1) STOCK NUMBER column. This column lists the NSN by National item identification number (NIIN) sequence. The NIIN consists of the last nine

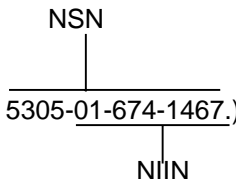

digits of the NSN (i.e., 5305-01-674-1467.)

When using this column to locate an item, ignore the first 4 digits of the NSN. However, the complete NSN should be used when ordering items by stock number.

(2) FIG. column This column lists the number of the figure where the item is identified/located. The figures are in numerical order in Section II and Section III.

(3) ITEM column. The item number identifies the item associated with the figure listed in the adjacent FIG. column. This item is also identified by the NSN listed on the same line.

b. PART NUMBER INDEX. Part numbers in this index are listed by part number in ascending alphanumeric sequence (i.e., vertical arrangement of letter and number combination which places the first letter or digit of each group in order A through Z, followed by the numbers 0 through 9 and each following letter or digit in like order.)

(1) FSCM column. The Commercial and Governmental Entity (CAGE) Code (C) is a 5 digit numeric code used to identify the manufacturer, distributor, or Government agency, etc., that supplies the item.

(2) PART NUMBER column. Indicates the primary number used by the manufacturer (individual, firm, corporation, or Government activity), which controls the design and characteristics of the item by means of its engineering drawings, specifications standards, and inspection requirements to identify an item or range of items.

(3) STOCK NUMBER column. This column lists the NSN for the associated part number and manufacturer identified in the PART NUMBER and CAGE columns to the left.

(4) FIG. column. This column lists the number of the figure where the item is identified/located in Section II and III.

(5) ITEM column. The item number is that number assigned to the item as it appears in the figure referenced in the adjacent figure number column.

c. FIGURE AND ITEM NUMBER INDEX.

(1) FIG. column. This column lists the number of the figure where the item is identified/located in Section II and III.

(2) ITEM column. The item number is that number assigned to the item as it appears in the figure referenced in the adjacent figure number column.

(3) STOCK NUMBER column. This column lists the NSN for the item.

(4) CAGE column. The Commercial and Governmental Entity (CAGE) Code (C) is a 5-digit numeric code used to identify the manufacturer, distributor, or Government agency, etc., that supplies the item.

(5) PART NUMBER column. Indicates the primary number used by the manufacturer (individual, firm, corporation, or Government activity), which controls the design and characteristics of the item by means of its engineering drawings, specifications standards, and inspection requirements to identify an item or range of items.

5. Special Information.

Use the following subparagraphs as applicable:

a. USABLE ON CODE. Not applicable.

b. FABRICATION INSTRUCTIONS. Bulk materials required to manufacture items are listed in the Bulk Material Functional Group of this RPSTL. Part numbers for bulk materials are also referenced in the description column of the line item entry for the item to be manufactured/fabricated. Detailed fabrication instructions for items source coded to be manufactured or fabricated are found in TM 5-3810-303-24.

c. KITS. Line item entries for repair parts kits appear in group 9401 in Section II.

d. INDEX NUMBERS. Items which have the word BULK in the figure column will have an index number shown in the item number column. This index number is a cross-reference between the National Stock Number/Part Number Index and the bulk material list in Section II.

e. ASSOCIATED PUBLICATIONS. The publications listed below pertain to the Crane Fairlead and Laggings:

Publication	Short Title
TM 5-3810-303-10	40 Ton Crane Crawler
TM 5-3810-303-24	40 Ton Crane Crawler
TM 5-3810-303-24P	40 Ton Crane Crawler
TM 5-3815-221-14&P	Backhoe
TM 5-3815-222-14&P	Shovel
TM 5-3815-224-14&P	Inserts and Jabs

6. How to locate Repair Parts.

a. *When National Stock Number or Part Number is Not Known.*

(1) First. Using the table of contents, determine the assembly group or subassembly group to which the item belongs. This is necessary since figures are prepared for assembly groups and subassembly groups, and listings are divided into the same groups.

(2) Second. Find the figure covering the assembly group or subassembly group to which the item belongs.

(3) Third. Identify the item on the figure and use the Figure and Item Number Index to find the NSN.

b. *When National Stock Number or Part Number is Known:*

(1) *First* Using the National Stock Number or the Part Number Index, find the pertinent National Stock Number or Part Number. The NSN index is in National Item Identification Number (NIIN) sequence (see 4.a(1)). The part numbers in the Part Number index are listed in ascending alphanumeric sequence (see 4.b). Both indexes cross-reference you to the illustration/figure and item number of the item you are looking for.

(2) *Second*. Turn to the figure and item number, verify that the item is the one you're looking for, then locate the item number in the repair parts list for the .figure .

7. Abbreviations.

For standard abbreviations see MIL-STD-12D, Military Standard Abbreviations For Use On Drawings, Specifications, Standards And In Technical Documents.

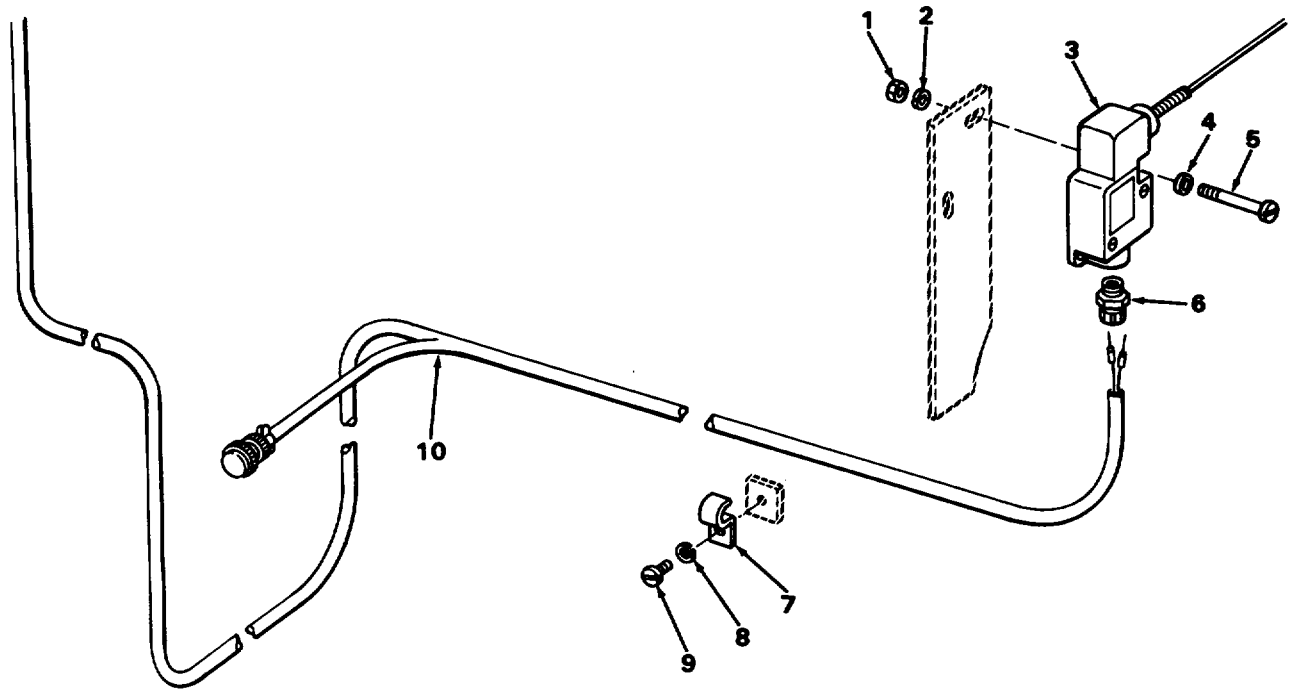

Figure 1. Fairlead limit switch.

TA272260

SECTION II

(1) ITEM NO	(2) SMR CODE	(3) CAGEC	(4) PART NUMBER	(5) DESCRIPTION AND USABLE ON CODE (UOC)	(6) QTY
GROUP 06 ELECTRICAL SYSTEM GROUP 0608 MISCELLANEOUS ITEMS FIG. 1 FAIRLEAD LIMIT SWITCH					
1	PAOZZ	96906	MS35649-202	NUT,PLAIN*HEXAGON	2
2	PAOZZ	96906	M53533-43	WASHER, LOCK	2
3	PFOZZ	91929	LZJ3-7B	SWITCH, SENSITIVE	1
4	PAOZZ	96906	MS2'7183-42	WASHER,FLAT	2
5	PAOZZ	96906	S35206-271	SCREW,MACHINEC	2
6	PFOZZ	03743	CG-1850	ADAPTER CONNECTOR	1
7	PFOZZ	75272	CH-0607	STRAP,RETANING	6
8	PAOZZ	96906	MS35338-43	WASHER LOCK	6
9	PAOZZ	96906	MS35206-261	SCREW, MACHINE	6
10	PFOZZ	27315	79Q922	WIRING HARNESS,BRAN	1
END OF FIGURE					

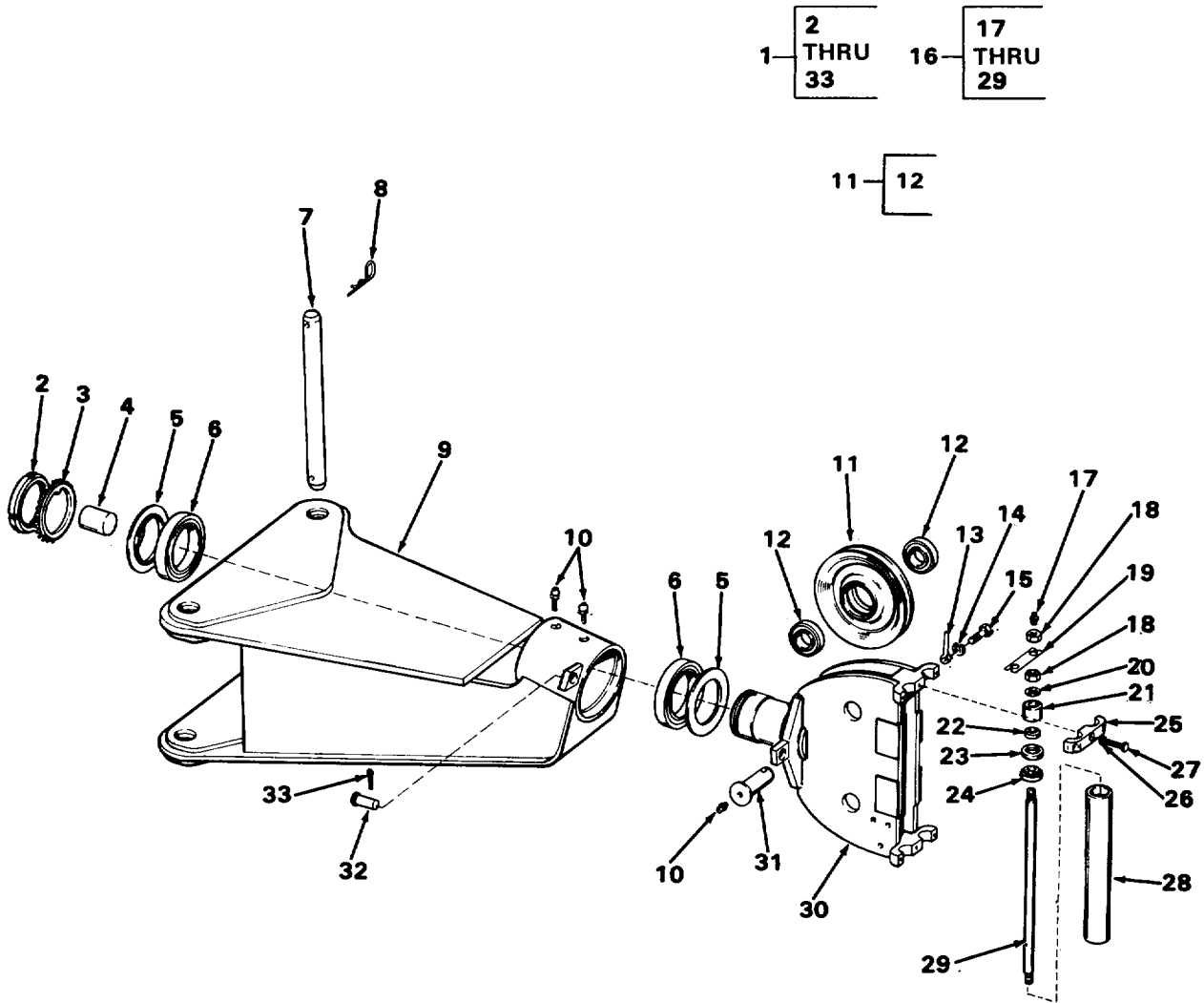

Figure 2. Fairlead dragline.

TA272261

SECTION II

(1) ITEM NO	(2) SMR CODE	(3) CAGEC	(4) PART NUMBER	(5) DESCRIPTION AND USABLE ON CODE (UOC)	(6) QTY
GROUP 74 CRANE ATTACHMENTS					
GROUP 7411 CRANE DRAGLINE OR CLAMSHELL ATTACHMENTS					
FIG. 2 FAIRLEAD DRAGLINE					
* 1	PFOOO	27315	2100J1036-3	FAIRLEADISHEAVE	1
2	PFOZZ	80064	AN28	NUT,PLAIN,ROUND	1
3	PFOZZ	52676	W-28	WASHER,KEY	1
4	PFOZZ	27315	18T6046	SPACER,SLEEVE	1
5	PFOZZ	27315	18T6045	PLATE,RETAINING,BEA	2
6	PFOZZ	43334	73L28	BEARING,BALL,ANNULA	2
7	PAOZZ	27315	219T524	ROD,STRAIGHT,HEADLE	2
8	PFOZZ	27315	20Z939D6	PINILOCK	2
9	PFOZZ	27315	216J124	FAIRLEAD,TUBULAR	1
10	PAOZZ	96906	MS15004-1	FITTING,LUBRICATION	4
11	PFOZZ	27315	7P793F1	PULLEY,GROOVE	2
12	PFOZZ	43334	8511	BEARING,BALL,ANNULA.	2
13	PFOZZ	27315	220T18	PLUG,MACHINE THREAD	2
14	PAOZZ	96906	MS35340-48	WASHER,LOCK	2
15	PAOZZ	96906	MS18154-113	SCREW,CAP,HEXAGON H	2
16	PFOFF	27315	913N9-1	FAIRLEAD,ROLLER	1
17	PAOZZ	96906	MS15004-2	FITTING,LUBRICATION	4
18	PAOZZ	96906	MS35691-65	NUT,PLAIN,HEXAGON	8
19	PFOZZ	27315	29T1862	PLATE	2
20	PAOZZ	96906	MS27183-25	WASHERFLAT	4
21	PFOZZ	27315	16T1894	SUPPORT ROLLER	2
22	PFOZZ	27315	25T993	BEARING,SLEEVE	4
23	PFOZZ	80201	17340	SEAL,PLAIN ENCASED	4
24	XDOZZ	60038	15113-15245	BEARING,ROLLER,TAPE	4
25	PFOZZ	27315	205T98	PAWL	4
26	PAOZZ	96906	M535340-48	WASHER,LOCK	6
27	PAOZZ	96906	M5S51095-416	*.SCREW,CAP,HEXAGON H	6
28	PFOZZ	27315	13P457	ROLLER,FAIRLEAD	2
29	PFOZZ	27315	19T4387	PIN	2
30	PFOZZ	27315	8N310	BRACKET,EYE,ROTATIN	1
31	PFOZZ	27315	19T4386	POST,ELECTRICAL-MEC	2
32	PFOZZ	27315	19T3650018	PIN,STRAIGHT,HEADED	1
* 33	XDOZZ	96652	LHCOT-3	*PIN,LOCK	1

END OF FIGURE

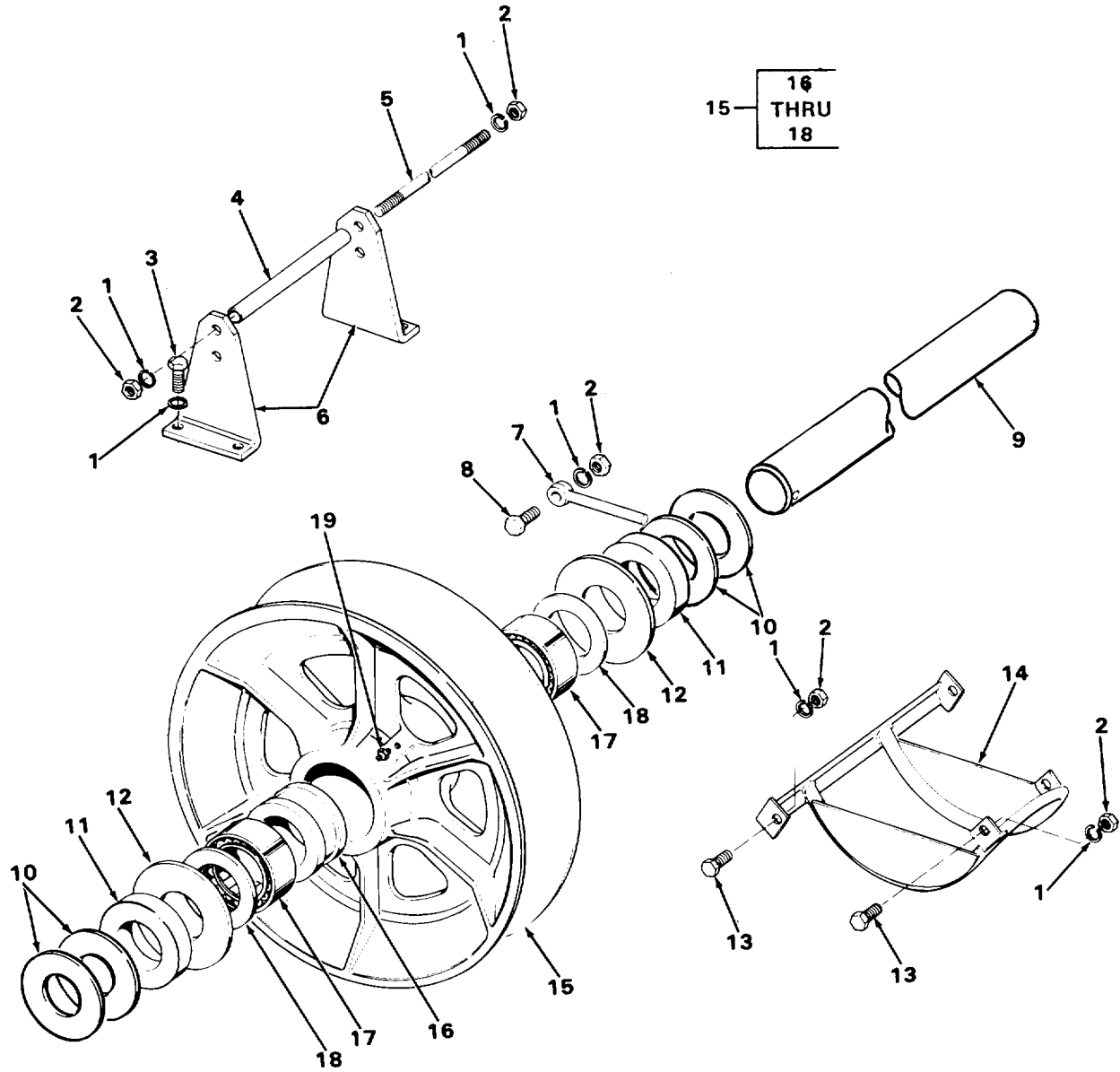

TA272262

Figure 3. Sheave boom point.

SECTION II

(1) ITEM NO	(2) SMR CODE	(3) CAGEC	(4) PART NUMBER	(5) DESCRIPTION AND USABLE ON CODE (UOC)	(6) QTY
GROUP 7411 CRANE DRAGLINE OR CRANE ATTACHMENTS					
FIG. 3 SHEAVE BOOM POINT					
1	PAOZZ	96906	5S35340-5t	WASHER,LOCK	2
2	PAOZZ	96906	MS51967-23	NUT, PLAIN, HEXAGON	8
3	PAOZZ	96906	S90725-186	SCREW,CAP,HEXAGON H	4
4	XDOZZ	27315	18P9330436	SPACER, SWLEEVE	1
5	PFOZZ	27315	320H684D23	ROD,THREADED END	1
6	PFOZZ	27315	16[2066	8RACKE, [ANGLE	2
7	PFOZZ	27315	ZOT4058	CONNECTOR,ROD END	2
8	PAOZZ	96906	NS90725-187	SCREW.CAP,HEXAGON H	2
9	PAOZZ	27315	19T4055	ROD,STRAIGHT,HEADLE	1
10	PFOZZ	27315	18H3892D0S7	WASHER,FLAT	4
11	PFOZZ	27315	18T11211	WASHER,FLAT.	2
12	PFOZZ	27315	18T6989	WASHER,FLAT	2
13	PAOZZ	96906	MS90728-185	SCREW,CAP,HEXAGON H,	4
14	PFOZZ	27315	214N235	GUARD. MECHANICAL DR	1
15	PFOHH	27315	7P691F1	PULLEY,GROCV	1
16	PFOZZ	27315	18T5831	SPACER,SLEEVE	1
17	PFOZZ	51588	CI216	BEARING, ROLLER, JOUR	2
18	PFOZZ	27315	18T5203	WASHER FLAT	2
19	PAOZZ	96906	MS1500,-2	FITTING,LU8RICATION	1
END OF FIGURE					

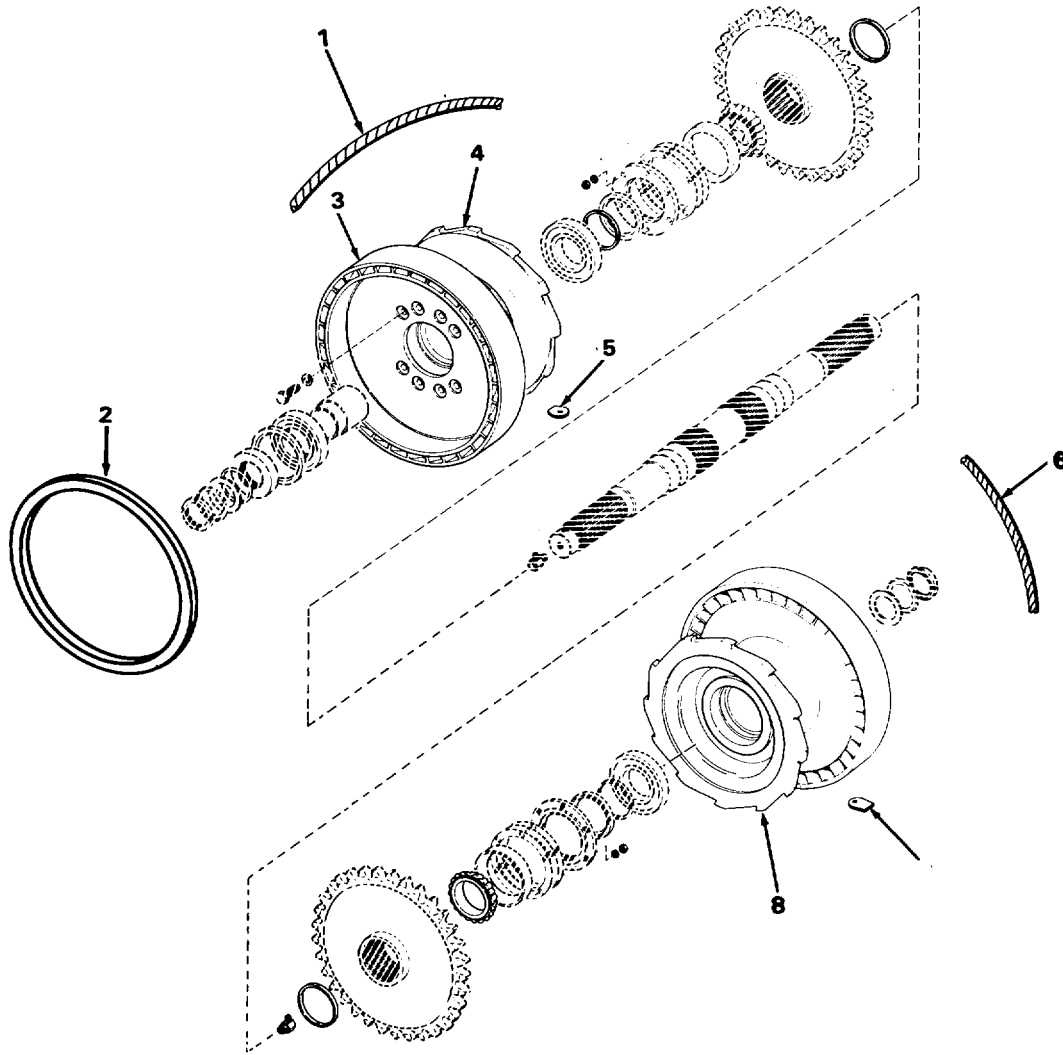

TA272263

Figure 4. Dragline drum and laggings.

SECTION II

(1) ITEM NO	(2) SMR CODE	(3) CAGEC	(4) PART NUMBER	(5) DESCRIPTION AND USABLE ON CODE (UOC)	(6) QTY
GROUP 7416 SHAFTS					
FIG. 4 DRAGLINE DRUM AND LAGGINGS					
1	MFOZZ	80967	14321-75	WIRE ROPELINE MAKE FROM WIRE ROPE V P/N 14321-500t 75-FEET LONG.	
* 2	XDOZZ	27315	45Z91D48	PREFORMED GASKET	1
3	PFOZZ	27315	223J101	BRAKE DRUM	1
4	PFOZZ	27315	223J108F1	LAGGINGHOISTING DR	1
5	PFOZZ	27315	208T1D	WEDGE, WIRE ROPE SOC	1
* 6	MFOZZ	80967	12401-140	WIRE ROPE MAKE FROM WIRE ROPE P/N V 12401-500 140-FEET LONG	
7	PFOZZ	27315	208T10	WEDGE	1
8	PFOZZ	27315	223J103F1	LAGGING,HOISTING OR	1
END OF FIGURE					

SECTION II

(1) ITEM NO	(2) SMR CODE	(3) CAGEC	(4) PART NUMBER	(5) DESCRIPTION AND USABLE ON CODE (UOC)	(6) QTY
				GROUP 95 GENERAL USE STANDARDIZED PARTS	
				GROUP 9501 HARDWARE SUPPLIES AND BULK MATERIEL, COMMON	
				FIG. BULK	
1	PAOZZ	80967	14321-500	ROPE, WIRE	1
* 2	PAOZZ	80967	12401-500	ROPE, WIRE	1
				END OF FIGURE	

BULK-1

CROSS- REFERENCE-INDEXES
NATIONAL STOCK NUMBER INDEX

STOCK NUMBER	FIG.	ITEM	STOCK NUMBER	FIG.	ITEM
5310-00-014-5850	1	4	5315-01-172-1024	2	32
5310-00-045-3296	1	2	5340-01-172-2829	2	7
	1	8	5340-01-172-2830	3	9
5305-00-050-4212	3	3	4010-01-174-2787	BULK	1
5310-00-052-6454	3	1	5365-01-177-3940	2	13
3110-00-061-8011	2	6	3120-01-177-7924	2	22
3110-00-157-6029	2	12	4010-01-184-0847	BULK	2
4730-00-172-0040	2	10	3815-01-185-6741	2	16
4730-00-172-0041	2	17	3110-01-186-7176	3	17
	3	19	5995-01-192-6354	1	10
5310-00-185-6338	2	2	5930-01-195-2330	1	3
5310-00-186-0984	2	3	5340-01-195-5460	2	19
4030-00-225-1435	4	7	5315-01-196-0515	2	8
3815-00-313-2428	2	1	3110-01-196-2694	2	5
5340-00-454-0509	2	25	5315-01-197-4883	2	29
5330-00-737-2477	2	23	3815-01-253-7357	2	21
5310-00-763-8921	3	2			
5310-00-809-8540	2	20			
5310-00-834-7606	2	14			
	2	26			
5310-00-891-3425	2	18			
5305-00-900-1118	3	13			
5305-00-915-8087	2	15			
5310-00-934-9758	1	1			
5305-00-939-9204	3	8			
5935-00-947-6177	1	6			
5305-00-964-0589	2	27			
5305-00-984-6208	1	9			
5305-00-984-6218	1	5			
3810-01-168-6429	4	4			
3810-01-168-6430	4	8			
4030-01-168-7282	4	5			
2530-01-169-1986	4	3			
5310-01-169-2924	3	18			
5340-01-169-5690	3	7			
5306-01-169-6449	3	5			
5340-01-169-6732	2	9			
3815-01-169-8727	2	28			
3020-01-170-1431	2	11			
3020-01-170-1432	3	15			
5310-01-170-6262	3	10			
5365-01-170-6353	2	4			
5365-01-170-6354	3	16			
5310-01-170-8537	3	12			
5310-01-170-8538	3	11			
5340-01-171-4037	1	7			
3815-01-171-5109	3	14			
5340-01-171-5320	3	6			
5340-01-172-0339	2	31			
3810-01-172-0859	2	30			

**NATIONAL STOCK NUMBER AND PART NUMBER INDEX
PART NUMBER INDEX**

CAGEC	PART NUMBER	STOCK NUMBER	FIG.	ITEM
80064	AN28	5310-00-185-6338	2	2
03743	CG-1850	5935-00-947-6177	1	6
75272	CH-0607	5340-01-171-4037	1	7
51588	CW216	3110-01-186-7176	3	17
96652	LHCOT-3		2	33
91929	LZJ3-78	5930-01-195-2330	1	3
96906	MS15004-1	4730-00-172-0040	2	10
96906	MS15004-2	4730-00-172-0041	2	17
			3	19
96906	MS18154-113	5305-00-915-8087	2	15
96906	MS27183-25	5310-00-809-8540	2	20
96906	MS27183-42	5310-00-014-5850	1	4
96906	MS35206-261	5305-00-984-6208	1	9
96906	MS35206-271	5305-00-984-6218	1	5
96906	MS35338-43	5310-00-045-3296	1	2
			1	8
96906	MS35340-48	5310-00-834-7606	2	14
			2	26
96906	MS35340-51	5310-00-052-6454	3	1
96906	MS35649-202	5310-00-934-9758	1	1
96906	MS35691-65	5310-00-891-3425	2	18
96906	MS51095-416	5305-00-964-0589	2	27
96906	MS51967-23	5310-00-763-8921	3	2
96906	MS90725-186	5305-00-050-4212	3	3
96906	MS90725-187	5305-00-939-9204	3	8
96906	MS90728-185	5305-00-900-1118	3	13
52676	W-28	5310-00-186-0984	2	3
80967	12401-140		4	6
80967	12401-500	4010-01-184-0847	BULK	2
27315	13P457	3815-01-169-8727	2	28
80967	14321-500	4010-01-174-2787	BULK	1
80967	14321-75		4	1
60038	15113-15245		2	24
27315	1611894	3815-01-253-7357	2	21
27315	16T2066	5340-01-171-5320	3	6
80201	17340	5330-00-737-2477	2	23
27315	18H3892D97	5310-01-170-6262	3	10
27315	18P933D436		3	4
27315	18T11211	5310-01-170-8538	3	11
27315	18T5203	5310-01-169-2924	3	18
27315	18T5831	5365-01-170-6354	3	16
27315	18T6045	3110-01-196-2694	2	5
27315	18T6046	5365-01-170-6353	2	4
27315	18T6989	5310-01-170-8537	3	12
27315	19T3650D18	5315-01-172-1024	2	32
27315	19T4055	5340-01-172-2830	3	9
27315	19T4386	5340-01-172-0339	2	31
27315	9T4387	5315-01-197-4883	2	29
27315	20T4058	5340-01-169-5690	3	7
27315	202939D6	5315-01-196-0515	2	8
27315	205T98	5340-00-454-0509	2	25

NATIONAL STOCK NUMBER AND PART NUMBER INDEX
PART NUMBER INDEX

CAGEC	PART NUMBER	STOCK NUMBER	FIG.	ITEM
27315	208T10	4030-00-225-1435	4	7
27315	208T18	4030-01-168-7282	4	5
27315	2100J1036-3	3815-00-313-2428	2	1
27315	214N235	3815-01-171-5109	3	14
27315	216J124	5340-01-169-6732	2	9
27315	219T524	5340-01-172-2829	2	7
27315	220T18	5365-01-177-3940	2	13
27315	223J101	2530-01-169-1986	4	3
27315	223J103F1	3810-01-168-6430	4	8
27315	223J108F1	3810-01-168-6429	4	4
27315	25T993	3120-01-177-7924	2	22
27315	29T1862	5340-01-195-5460	2	19
27315	320H684D23	5306-01-169-6449	3	5
27315	45Z91048		4	2
27315	7P691F1	3020-01-170-1432	3	15
27315	7P793F1	3020-01-170-1431	2	11
43334	73L28	3110-00-061-8011	2	6
27315	79Q922	5995-01-192-8354	1	10
27315	8N310	3810-01-172-0859	2	30
43334	8511	3110-00-157-6029	2	12
27315	913N9-1	3815-01-185-6741	2	16

CROSS REFERENCE INDEXES

FIG.	ITEM	FIGURE AND ITEM NUMBER INDEX STOCK NUMBER	CAGEC	PART NUMBER
BULK	1	4010-01-174-2787	80967	14321-500
BULK	2	4010-01-184-0847	80967	12401-500
1	1	5310-00-934-9758	96906	MS35649-202
1	2	5310-00-045-3296	96906	MS35338-43
1	3	5930-01-195-2330	91929	LZJ3-78
1	4	5310-00-014-5850	96906	MS27183-42
1	5	5305-00-984-6218	96906	MS35206-271
1	6	5935-00-947-6177	03743	CG-1850
1	7	5340-01-171-4037	75272	CH-0607
1	8	5310-00-045-3296	96906	MS35338-43
1	9	5305-00-984-6208	96906	MS35206-261
1	10	5995-01-192-8354	27315	79Q922
2	1	3815-00-313-2428	27315	2100J1036-3
2	2	5310-00-185-6338	80064	AN28
2	3	5310-00-186-0984	52676	W-28
2	4	5365-01-170-6353	27315	18T6046
2	5	3110-01-196-2694	27315	18T6045
2	6	3110-00-061-8011	43334	73L28
2	7	5340-01-172-2829	27315	219T524
2	8	5315-01-196-0515	27315	202Z939D6
2	9	5340-01-169-6732	27315	216J124
2	10	4730-00-172-0040	96906	MS15004-1
2	11	3020-01-170-1431	27315	7P793F1
2	12	3110-00-157-6029	43334	8511
2	13	5365-01-177-3940	27315	220T18
2	14	5310-00-834-7606	96906	M535340-48
2	15	5305-00-915-8087	96906	MS18154-113
2	16	3815-01-185-6741	27315	913N9-1
2	17	4730-00-172-0041	96906	MS15004-2
2	18	5310-00-891-3425	96906	MS35691-65
2	19	5340-01-195-5460	27315	29T1862
2	20	5310-00-809-8540	96906	MS27183-25
2	21	3815-01-253-7357	27315	16T1894
2	22	3120-01-177-7924	27315	25T993
2	23	5330-00-737-2477	80201	17340
2	24		60038	15113-15245
2	25	5340-00-454-0509	27315	205T98
2	26	5310-00-834-7606	96906	MS35340-48
2	27	5305-00-964-0589	96906	MS51095-416
2	28	3815-01-169-8727	27315	13P457
2	29	5315-01-197-4883	27315	19T4387
2	30	3810-01-172-0859	27315	8N310
2	31	5340-01-172-0339	27315	19T4386
2	32	5315-01-172-1024	27315	19T3650018
2	33		96652	LHCOT-3
3	1	5310-00-052-6454	96906	MS35340-51
3	2	5310-00-763-8921	96906	MS51967-23
3	3	5305-00-050-4212	96906	M£90725-186
3	4		27315	18P9330436
3	5	5306-01-169-6449	27315	320H684023
3	6	5340-01-171-5320	27315	16T2066

CROSS REFERENCE INDEXES

FIG.	ITEM	FIGURE AND ITEM NUMBER INDEX STOCK NUMBER	CAGEC	PART NUMBER
3	7	5340-01-169-5690	27315	20T4058
3	8	5305-00-939-9204	96906	MS90725-187
3	9	5340-01-172-2830	27315	19T4055
3	10	5310-01-170-6262	27315	18H3392D97
3	11	5310-01-170-8538	27315	18T11211
3	12	5310-01-170-8537	27315	1816989
3	13	5305-00-900-1118	96906	MS90728-185
3	14	3815-01-171-5109	27315	214N235
3	15	3020-01-170-1432	27315	7P691F1
3	16	5365-01-170-6354	27315	18T5831
3	17	3110-01-186-7176	51588	CW216
3	18	5310-01-169-2924	27315	18T5203
3	19	4730-00-172-0041	96906	MS15004-2
4	1		80967	14321-75
4	2		27315	45Z910D4
4	3	2530-01-169-1986	27315	223J101
4	4	3810-01-168-6429	27315	223J108F1
4	5	4030-01-168-7282	27315	208T18
4	6		80967	12401-140
4	7	4030-00-225-1435	27315	208T10
4	8	3810-01-168-6430	27315	223J103F1

*U.S GOVERNMENT PRIING OF RCE 1993- 746-017/80041

THE METRIC SYSTEM AND EQUIVALENTS

LINEAR MEASURE

- 1 Centimeter = 10 Millimeters = 0.01 Meters = 0.3937 Inches
- 1 Meter = 100 Centimeters = 1,000 Millimeters = 39.37 Inches
- 1 Kilometer = 1,000 Meters = 0.621 Miles

SQUARE MEASURE

- 1 Sq Centimeter = 100 Sq Millimeters = 0.155 Sq Inches
- 1 Sq Meter = 10,000 Sq Centimeters = 10.76 Sq Feet
- 1 Sq Kilometer = 1,000,000 Sq Meters = 0.386 Sq Miles

CUBIC MEASURE

- 1 Cu Centimeter = 1,000 Cu Millimeters = 0.06 Cu Inches
- 1 Cu Meter = 1,000,000 Cu Centimeters = 35.31 Cu Feet

LIQUID MEASURE

- 1 Milliliter = 0.001 Liters = 0.0338 Fluid Ounces
- 1 Liter = 1,000 Milliliters = 33.82 Fluid Ounces

TEMPERATURE

- $5/9 (^{\circ}\text{F} - 32) = ^{\circ}\text{C}$
- 212 $^{\circ}$ Fahrenheit is equivalent to 100 $^{\circ}$ Celsius
- 90 $^{\circ}$ Fahrenheit is equivalent to 32.2 $^{\circ}$ Celsius
- 32 $^{\circ}$ Fahrenheit is equivalent to 0 $^{\circ}$ Celsius
- $9/5 \text{ C}^{\circ} + 32 = \text{F}^{\circ}$

WEIGHTS

- 1 Gram = 0.001 Kilograms = 1,000 Milligrams = 0.035 Ounces
- 1 Kilogram = 1,000 Grams = 2.2 lb.
- 1 Metric Ton = 1,000 Kilograms = 1 Megagram = 1.1 Short Tons

APPROXIMATE CONVERSION FACTORS

TO CHANGE	TO	MULTIPLY BY
Inches	Centimeters	2.540
Feet	Meters	0.305
Yards	Meters	0.914
Miles	Kilometers	1.609
Square Inches	Square Centimeters	6.451
Square Feet	Square Meters	0.093
Square Yards	Square Meters	0.836
Square Miles	Square Kilometers	2.590
Acres	Square Hectometers	0.405
Cubic Feet	Cubic Meters	0.028
Cubic Yards	Cubic Meters	0.765
Fluid Ounces	Milliliters	29.573
Pints	Liters	0.473
Quarts	Liters	0.946
Gallons	Liters	3.785
Ounces	Grams	28.349
Pounds	Kilograms	0.454
Short Tons	Metric Tons	0.907
Pound-Feet	Newton-Meters	1.356
Pounds Per Square Inch	Kilopascals	6.895
Miles Per Gallon	Kilometers Per Liter	0.425
Miles Per Hour	Kilometers Per Hour	1.609
TO CHANGE	TO	MULTIPLY BY
Centimeters	Inches	0.394
Meters	Feet	3.280
Meters	Yards	1.094
Kilometers	Miles	0.621
Square Centimeters	Square Inches	0.155
Square Meters	Square Feet	10.764
Square Meters	Square Yards	1.196
Square Kilometers	Square Miles	0.386
Square Hectometers	Acres	2.471
Cubic Meters	Cubic Feet	35.315
Cubic Meters	Cubic Yards	1.308
Milliliters	Fluid Ounces	0.034
Liters	Pints	2.113
Liters	Quarts	1.057
Liters	Gallons	0.264
Grams	Ounces	0.035
Kilograms	Pounds	2.205
Metric Tons	Short Tons	1.102
Newton-Meters	Pound-Feet	0.738
Kilopascals	Pounds Per Square Inch	0.145
Kilometers Per Liter	Miles Per Gallon	2.354
Kilometers Per Hour	Miles Per Hour	0.621

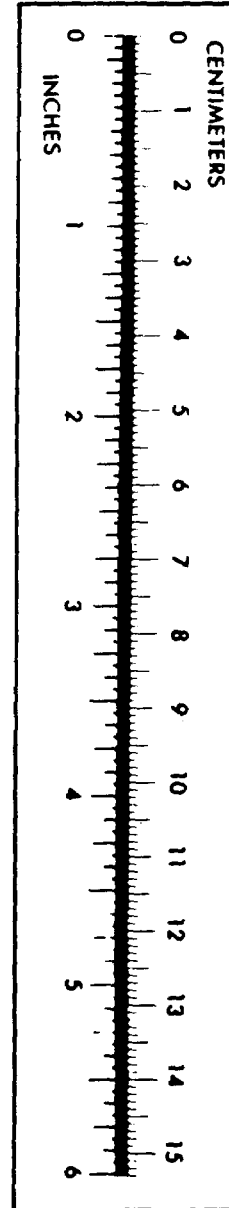

CASTING THE DRAGLINE BUCKET. Casting the bucket adds 10 to 20 feet to the effective digging radius. After setting the boom angle, pull the hoist line lever and raise the bucket half the distance between the ground and the boom point. Depress the hoist line brake pedal and release the hoist line lever. Pull the dragline lever back and pull the bucket in toward the boom, then simultaneously release the dragline lever and the hoist line brake pedal allowing the bucket to cast out beyond the boom point. Accurate casting will come only with practice.

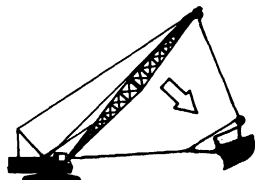

FILLING THE DRAGLINE BUCKET. After the bucket has been cast, pull the dragline lever back, dragging the bucket toward the machine. Ease up on the hoist line brake pedal allowing the hoist cable to reel off the drum so the bucket teeth continuously bite into the ground. When the bucket is full, release the dragline lever and depress both brake pedals.

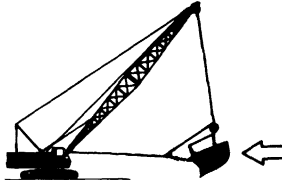

A1501

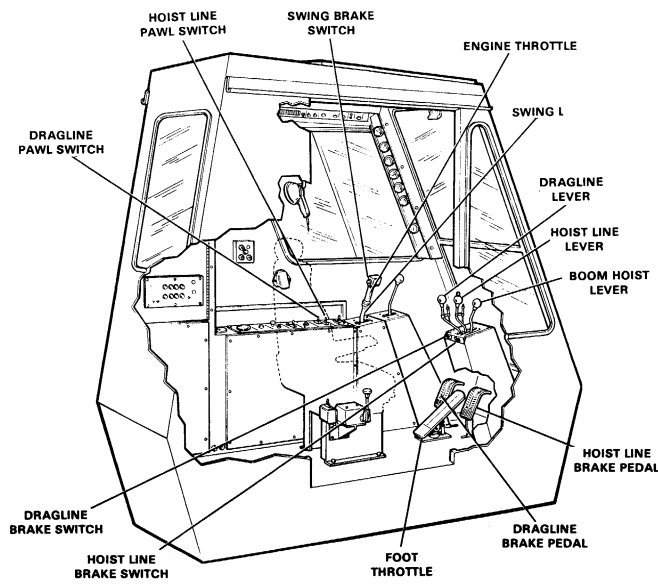

RAISING THE LOADED BUCKET. Pull the hoist line lever back and release the hoist line brake pedal. Ease up on the dragline brake pedal to hold the bucket level and prevent dumping as the bucket is raised. When the bucket reaches the desired height, apply the hoist line brake and return the hoist line lever to neutral. Apply the dragline brake.

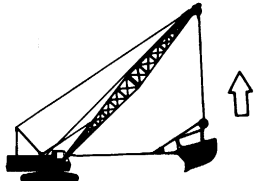

SWINGING. Keep both the drag and hoist line brakes on while swinging. Pull the swing lever back to swing to the right (away from the boom). Push the swing lever forward to swing the upper to the left (toward the boom). Engage the lever slowly so the swing is smooth. To stop or reverse the swing motion, slowly move the swing lever in the opposite direction (plugging the swing motion). Gently swing the bucket toward the dump pile.

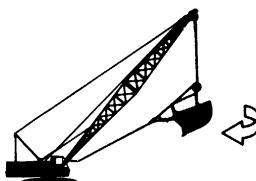

DUMPING. As the dump pile is approached, release the dragline brake pedal allowing the bucket to swing out and dump its load. When the bucket is dumped, apply the dragline brake to keep the cable taut and prevent unwinding. Swing the boom back, cast the dragline bucket and repeat the cycle.

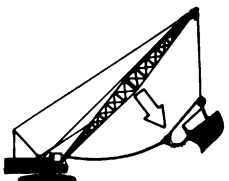

Dragline Operating Cycle

RECOMMENDED CHANGES TO EQUIPMENT TECHNICAL PUBLICATIONS



THEN... JOT DOWN THE DOPE ABOUT IT ON THIS FORM, CAREFULLY TEAR IT OUT, FOLD IT AND DROP IT IN THE MAIL!

SOMETHING WRONG WITH THIS PUBLICATION?

FROM: (PRINT YOUR UNIT'S COMPLETE ADDRESS)

DATE SENT

PUBLICATION NUMBER

PUBLICATION DATE

PUBLICATION TITLE

BE EXACT... PIN-POINT WHERE IT IS

PAGE NO.

PARA-GRAPH

FIGURE NO.

TABLE NO.

IN THIS SPACE TELL WHAT IS WRONG AND WHAT SHOULD BE DONE ABOUT IT:

TEAR ALONG PERFORATED LINE

PRINTED NAME, GRADE OR TITLE, AND TELEPHONE NUMBER

SIGN HERE:

DA FORM 2028-2 JUL 79

PREVIOUS EDITIONS ARE OBSOLETE.

P.S.—IF YOUR OUTFIT WANTS TO KNOW ABOUT YOUR RECOMMENDATION MAKE A CARBON COPY OF THIS AND GIVE IT TO YOUR HEADQUARTERS.

